

# PILE FOUNDATION DESIGN AND CONSTRUCTION PRACTICE: A MALAYSIAN CONSULTANT'S PERSPECTIVE

Yean-Chin TAN<sup>1</sup> and Chee-Meng CHOW<sup>1</sup>

<sup>1</sup> G&P Geotechnics Sdn Bhd, Kuala Lumpur, Malaysia (www.gnpgeo.com.my)

**Abstract :** Due to rapid development in the early 1990s, various types of pile foundation system have been designed and constructed in Malaysia. Pile foundations such as driven precast reinforced concrete square piles, bored piles and micropiles were already widely used in Malaysia and other relatively new foundation systems such as large diameter bored piles (3.0m diameter) and high capacity jack-in spun piles (capacity = 3000kN) were recently being introduced in Malaysia. Due to the challenges of urbanization where site with “good” soil is becoming increasingly rare, innovative foundation design approach is also required for civil engineering works in soft ground. Recent innovations include piled-strip-raft foundation system in very soft clay, high capacity jack-in piles for high-rise structures in congested urban areas and piled raft foundation system. This paper describes some of the relatively new foundation system introduced in Malaysia, its evolution and potential future applications. The paper also shares experience on foundation system such as jack-in piles and piled-strip-raft in soft ground where Malaysian engineers have accumulated considerable experience in the performance of such foundation system.

*Key words :* Pile foundation, limestone, jack-in pile, piled raft, soft clay.

## 1 INTRODUCTION

Since its independence in 1957, Malaysia has undergone rapid development and the development of geotechnical engineering practice in general, and specifically pile foundation design and construction have also progressed in tandem with the nation. Ting et al. (2004) briefly summarised some of the achievements made by geotechnical engineers in Malaysia in the area of pile foundation from the earliest form of “modern” pile foundation using reinforced concrete (RC) square pile with Grade 20 concrete; cast in-situ as there was then no pile manufacturing facilities, to the use of bored piles where considerable experience has been accumulated over the years (Mitchell, 1985, Toh et al., 1989 and Tan et al., 1998). Malaysian geotechnical engineers have also made significant contributions in the design and construction of micropiles (Chan & Ting, 1996 and Gue & Liew, 1998), foundations in limestones (Ting, 1985) and piled embankment (Chin, 1985). The experience gained in some major civil engineering projects such as the Penang Bridge – Figure 1 (Chin, 1988), North-South Expressway (PLUS, 1990), Petronas Twin Towers – Figure 2 (Azam et al., 1996), etc. have also led to innovations such as high capacity RC spun piles, understanding of arching mechanism using individual piles to support embankment and piled raft foundation system. Another worthy contribution in the practice of pile foundation is the method of predicting ultimate capacity of piles proposed by Chin (1970) and the diagnosis of pile conditions (Chin, 1978) which have gained worldwide recognition. It is the achievements of these early generations of geotechnical engineers in Malaysia which had subsequently inspired further innovations and developments in the practice of geotechnical engineering in Malaysia.



**Fig. 1** Penang Bridge.

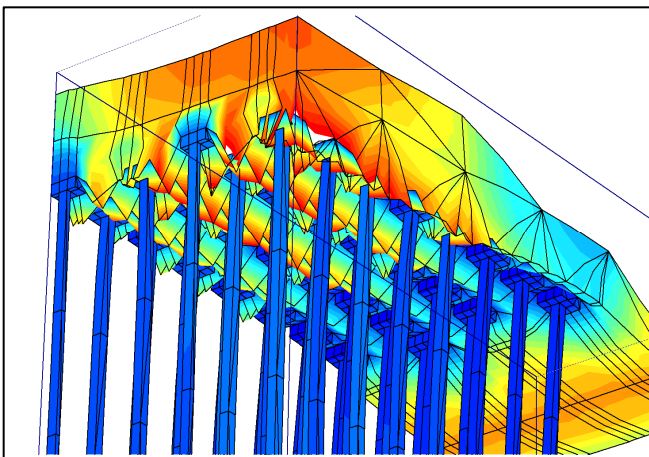


**Fig. 2** Petronas Twin Towers.

Some of the recent applications in pile design and construction introduced in Malaysia include large diameter bored piles (Figure 3) and understanding of arching mechanism associated with individual piles to support earth embankment, Figure 4 (Gue et al., 2007). In this paper, some recent developments in pile foundation design and construction practice from a Malaysian consultant's perspective are summarised.



**Fig. 3** Casing for 3.0m diameter bored pile.



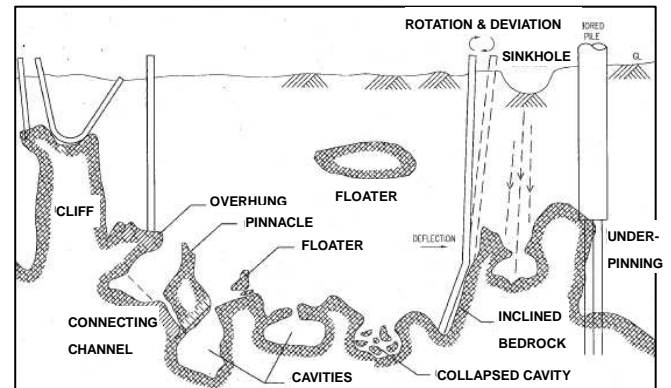
**Fig. 4** 3-D finite element modelling of arching mechanism.

## 2 PILE FOUNDATION IN LIMESTONE AREA

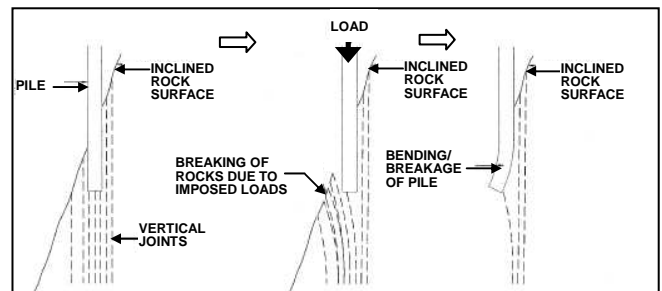
Limestone formation is widespread in Peninsular Malaysia with one-third of Kuala Lumpur (capital of Malaysia) situated on limestone formation. The limestone formation in Peninsular Malaysia is of Ordovician to Triassic age.

The design and construction of foundations in limestone areas have posed various problems to geotechnical engineers due to the karstic features of limestone such as steeply inclined bedrock, cavities, floaters, etc. Karst refers to a characteristic topographic feature or landscape which can be developed by rock undergoing dissolution by percolating meteoric water (Jakucs, 1977). In Peninsular Malaysia, under tropical humid conditions, calcite and dolomite

limestones or their metamorphised equivalents develop tropical features which show spectacular tall steep-sided hills (Jennings, 1982) and solution features such as pinnacles, sinkholes and cavities. The treacherous and almost unpredictable karstic bedrock associated with extremely variable overburden soil properties is a typical feature of limestone (Yeap, 1985), which leads to a variety of geotechnical problems and hazards. Ting (1985) and Gue (1999) discussed some of the common engineering problems associated with limestone formation and Figures 5 and 6 show some typical piling problems in limestone areas.



**Fig. 5** Some piling problems in limestone areas (Neoh, 1998).



**Fig. 6** Pile breakage in steeply inclined bedrock surface with adverse geological features.

In Malaysia, the design of pile foundations to cater for highly erratic bedrock profiles and sloping bedrock associated with limestone formation involves the following (Tan & Chow, 2006):

- i) Provision of compensation piles within the pile group (if necessary) to ensure that the induced rotation within the group is within tolerable limits, i.e. within the bending moment capacity of the pile and pilecap-column connection and no piles within the group are overstressed. This also applies in situations where significant differences in pile lengths are observed within the same pile group due to the highly irregular bedrock profile of limestone. Such large differences in pile lengths induce bending moments and also uneven distribution of loads within the pile group due to different magnitudes of elastic shortening of the piles. Therefore, provision for higher percentages of compensation piles is usually required for driven/jacked-in piles foundation in limestone area due to the complex geological settings of limestone

formation. In addition, the risk of pile damage during driving is also higher in limestone formation. This, however, can be minimised with use of proper Oslo shoe, competent site supervision and experienced contractors.

- ii) Provision of Oslo-point rock shoes (Bjerrum, 1957) in areas where the overburden soils are soft or loose to prevent pile deflection during installation and to ensure the pile toe is properly secured to the rock as illustrated in Figure 7. The hardness of the hardened steel used for Oslo-point rock shoes should be larger than 300 (Brinell hardness) and the yield strength of the rock shoe should not be less than 700 MPa. The rock shoe should be designed to take the full required load at the contact and extra care should be taken during construction to prevent altering its properties, in particular, by welding. Typical details of Oslo-point pile shoes are shown in Figure 8.
- iii) Adjustment of rock sockets based on the actual bedrock surface encountered during construction to ensure sufficient socket capacity for rock socketed bored piles or micropiles, especially in steeply inclined bedrock areas with adverse geological features or in pinnacle/cliff areas as illustrated in Figure 9. This illustrates the importance of input during construction for the successful design and construction of foundations in limestone areas. The information obtained during subsurface investigation (SI) can be greatly enhanced by input during construction as the bedrock level can be continuously updated as piling works progress. In addition, the inclination of the bedrock surface can be deduced based on the bedrock level as encountered during pile construction/installation, and refinement to design can then be continuously carried out as construction progresses.

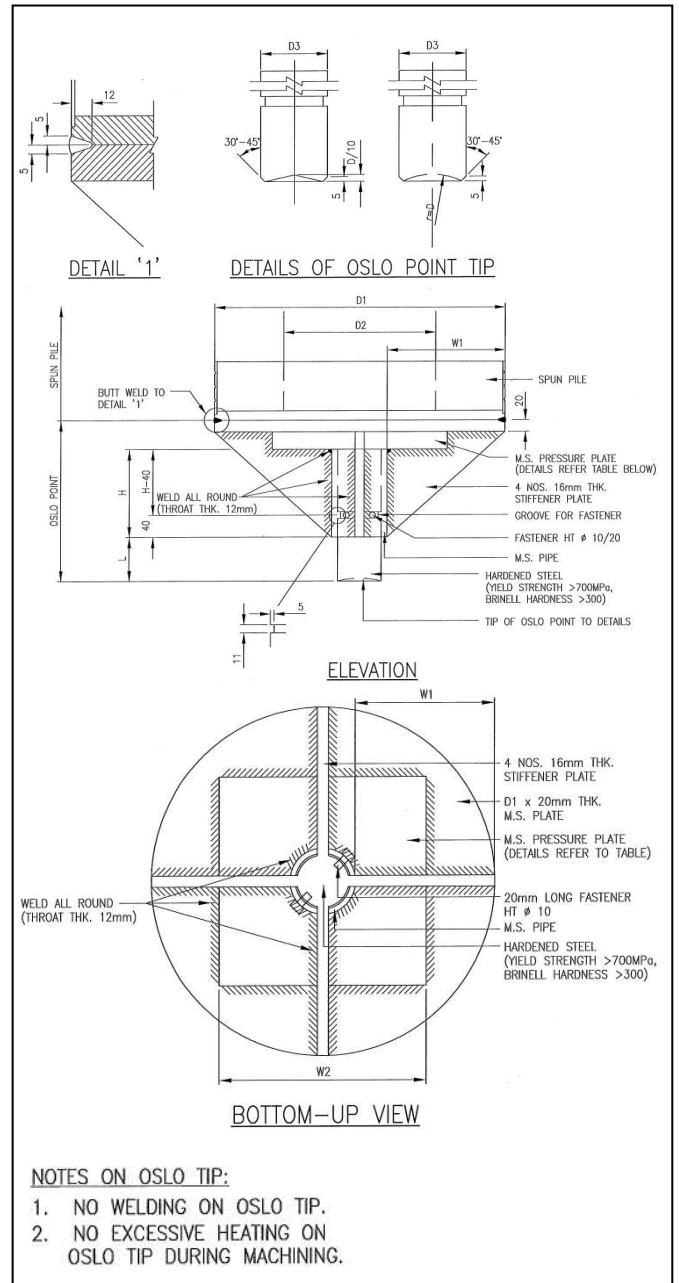


Fig. 8 Typical Oslo-point rock shoe details.

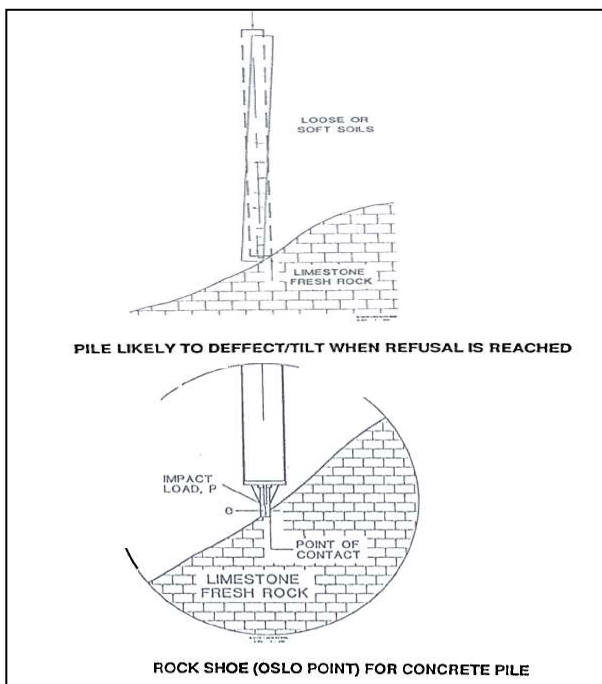


Fig. 7 Mechanism of Oslo-point (Gue, 1999).

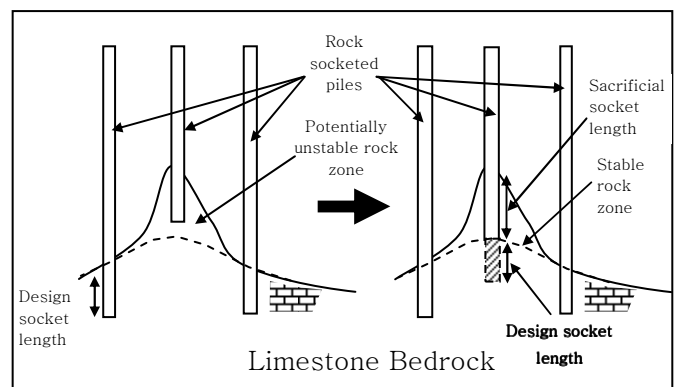
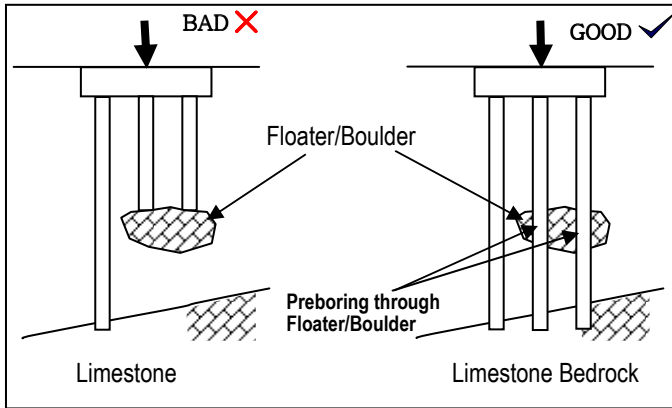


Fig. 9 Adjustment of rock socket length based on input during construction.

The effect of founding pile foundations on floating boulder as idealised in Figure 10 is that the axial load in the piles founded on the intended founding layer increases, while the axial load in the piles on the floater decreases. This will induce uneven settlement in the pile group and hence, rotation is developed which will induce bending moments in the piles at the pile heads and also causes potential overstressing of piles founded on the intended founding layer.



**Fig. 10** Pile foundation on floating boulders.

Therefore, to cater for such situations, the following is normally carried out:

- i) Preboring through floaters prior to installation of driven/jacked-in piles. This is to ensure that the piles reach the intended founding layer.
- ii) In the event that the driven/jacked-in piles terminate prematurely on a floater, provision of compensation piles should take into consideration the reduced capacity of the piles founded on the floater and the pilecap/tiebeam should be sufficiently stiff and adequately designed to span across the piles founded on floaters.

The essential steps for successful treatment of cavity and slump zone involve:

- i) Cavity and slumpzone probing
- ii) Injection of grout/mortar. Mortar is preferred due to its cost effectiveness and also easy to control at site.
- iii) Verification of cavity grouting

Cavity and slump zone probing should be carried out using a suitable drilling machine to a minimum depth of 10m into solid limestone if no cavity is encountered or 10m below the last cavity encountered. Based on the results of cavity and slump zone probing, the required treatment should be carried out using grout/mortar according to the following sequence:

- i) If there is more than one drill hole for treatment, generally mortar injection should commence around the perimeter of the treatment zone and then proceeding toward the centre. Each hole should be drilled and grouted before moving to the next hole.
- ii) In the case of multiple cavities or multiple limestone layers in any drill hole, treatment should proceed from the lowest cavity and completed for that cavity before

proceeding to the next higher cavity.

- iii) If required, packer(s) are to be adopted to prevent flow out of the grout/mortar before achieving the required criteria of acceptance or pressure specified. Each drill hole for grout treatment may be accompanied by at least one vent hole or pressure release hole of similar depth and size.

Acceptance criteria for cavity treatment using grout/mortar are commonly based on the following criteria:

- i) For soils within the treatment zone, the individual SPT-N values at any point are not less than 20 and the average SPT-N value is not less than 25
- ii) No void is encountered
- iii) Unconfined compressive strengths of the cores (if required) are in excess of  $2\text{N/mm}^2$  or other strength requirements as per design

Good construction practice is also very important to ensure successful installation of driven/jacked-in pile foundations in limestone areas especially for sites where steeply inclined bedrock and floaters are expected. Some good construction practices are summarized below:

- a) Based on available boreholes and cavity probing points, interpretation of the bedrock profile is carried out. The interpreted bedrock profile will serve as reference during pile driving where the hammer height is reduced when approaching the interpreted bedrock profile to prevent slip-off of pile point. However, the Engineer should be aware that the interpreted bedrock profile is only a rough guide as the limestone is usually highly irregular in depth and therefore, good engineering judgement must be exercised. When the pile point has come into contact with the rock surface which normally can be recognized by a sudden change in the response of the hammer, pile driving is then continued with a very small drop height of the ram (typically about 100mm to 200mm). After the pile has been subjected to a series of blows until the penetration of the pile is negligible, the fall is increased to double the height. The steps are repeated until the required termination criterion is achieved. This procedure is intended to socket the pile into competent bedrock and to prevent sliding of the pile point at the contact with the rock surface.
- b) Continuous monitoring through high strain dynamic pile test should be used to calibrate the permissible drop height to prevent damage to piles during installation of driven piles. It also serves as a useful tool for quality control during pile installation and detection of damaged piles. For preliminary estimation of pile driving criteria, methods based on wave equations, e.g. using software such as GRLWEAP, could be used to determine the permissible drop height and set criteria. The use of dynamic formulas (e.g. Hiley) is strongly discouraged as there is clear inadequacy of this method.
- c) In the event of premature pile termination due to the existence of intermediate hard lenses (high SPT-N

value) or small boulders, the problem can be overcome by applying a higher jack-in force or increasing the driving energy (a heavier hammer is preferred to higher drop heights to reduce potential pile damage). Again, the use of high strain dynamic pile tests is recommended to monitor pile stresses during installation of driven pile in such situations to ensure the compressive and tensile stresses induced in the pile are within tolerable limits.

### 2.1 Bored Pile in Limestone Area

In Malaysia, bored pile design in limestone is heavily dependent on semi-empirical methods. Generally, the design rock socket friction is a function of the surface roughness of rock sockets, the unconfined compressive strength of intact rock, the confining stiffness around the rock socket in relation to fractures of rock mass and socket diameter, and the geometry ratio of socket length-to-diameter. Roughness is an important factor in rock socket pile design as it has significant effects on the normal contact stress at the socket interface during shearing. The normal contact stress increases due to dilation, resulting in increased socket friction. The degree of dilation is mostly governed by the socket roughness. The second factor on the intact rock strength governs the ability of the irregular asperity of the socket interface transferring the shear force, otherwise shearing through the irregular asperity will occur due to highly concentrated shear forces from the socket. The third factor will govern the overall performance of strength and stiffness of the rock socket in jointed or fractured rock mass and the last factor is controlled by the profile of socket friction distribution. It is very complicated to quantify all of these aspects in rock socket pile design. Therefore, based on local experience, some conservative semi-empirical methods have evolved to facilitate quick and simple rock socket design taking into considerations the factors discussed above. In most cases, roughness of socket is only qualitatively assessed due to lack of systematic and reliable methods of assessment. The other three factors can be quantified through strength tests on the rock cores and point load tests on the recovered fragments, RQD values of the core samples and some analytical method of assessing the socket distribution. It is also customary and important to perform preliminary and working load tests to verify the rock socket design using such semi-empirical methods. A safety factor of two is a common requirement for rock socket pile design. Table 1 summarises typical design/working socket friction values for limestone formations in Malaysia.

Another more systematic approach developed by Rosenberg & Journeaux (1976), Horvath (1978) and Williams & Pells (1981) is also referred to in Malaysia. The following simple expression is used to compute the rock socket friction,  $f_s$  with consideration of the strength of intact rock and the rock mass effect due to discontinuities:

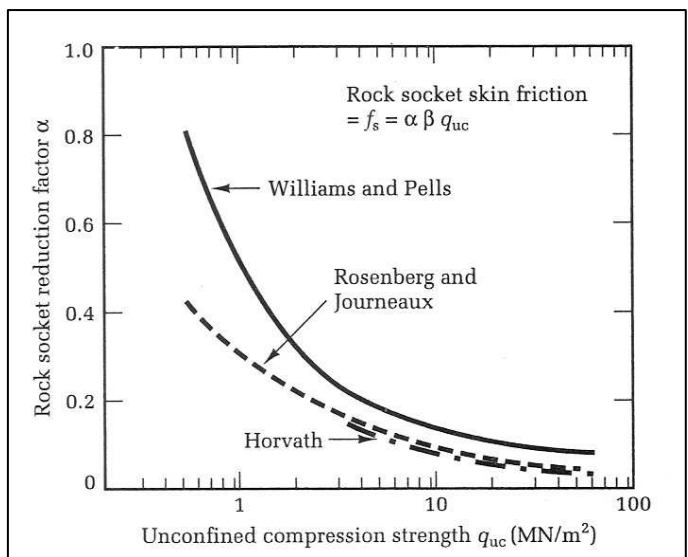
$$f_s = \alpha \cdot \beta \cdot q_{uc}$$

where

- $q_{uc}$  = unconfined compressive strength of intact rock
- $\alpha$  = reduction factor with respect to  $q_{uc}$  (Figure 11)
- $\beta$  = reduction factor with respect to rock mass effect (Figure 12)

**Table 1** Summary of Rock Socket Friction Design Values for Limestone Formations in Malaysia.

Working Rock Socket Friction	Remarks
300kPa for RQD < 30%	The working/design values given are subject to 0.05 x minimum of ( $q_{uc}$ , $f_{cu}$ ), whichever is smaller.
400kPa for RQD = 30%	
500kPa for RQD = 40%	
600kPa for RQD = 55%	
700kPa for RQD = 70%	
800kPa for RQD > 85%	
RQD = Rock Quality Designation	$q_{uc}$ = unconfined compressive strength of intact rock $f_{cu}$ = compressive strength of concrete/grout for piles



**Fig. 11** Rock socket reduction factor,  $\alpha$  (Tomlinson, 1995).



**Fig. 12** Rock socket reduction factor,  $\beta$  (Tomlinson, 1995).

During borehole exploration, statistics of  $q_{uc}$  can be compiled for different weathering grades of bedrock and the rock fracture can be assessed through the Rock Quality Designation; RQD on the rock core recovered or by interpretation of pressuremeter modulus in the rock mass against the elastic modulus of intact rock, which is equivalent to the mass factor,  $j$  which is the ratio of elastic modulus of rock mass to that of intact rock. In some cases, at very small cost, the point load test is used to assess and verify rock strength on recovered rock fragments during bored piling after proper calibration with borehole results.

In general, the contribution of base resistance in bored piles should be ignored due to difficulty in proper cleaning of base especially for wet hole construction (with drilling fluid). The contribution of base resistance can only be used if it is verified by results of instrumented test piles, the bored pile is constructed in dry holes, proper inspection of the base can be carried out, or if base grouting is implemented. Tan et al. (1998) reported low values of mobilised base resistance for bored piles in tropical residual soils where  $K_{bu}$  values of between 7 and 10 were obtained.  $K_{bu}$  is the ultimate base resistance factor for the semi-empirical correlations of base resistance with N-values from Standard Penetration Tests (SPT-N values) given in the equation below:

Ultimate base resistance,  $f_{bu} = K_{bu} \times \text{SPT-N}$  (in kPa)

The relatively low  $K_{bu}$  values are due to the soft toe effect which is very much dependent on workmanship and pile geometry. This is even more pronounced in long piles in wet holes.

In view of the difficulty of proper base cleaning, the authors strongly recommend ignoring the base contribution in bored pile design unless proper base cleaning can be assured and verified.

The construction method is also an important consideration in the design of bored piles in limestone formation. In Malaysia, the two most common methods of forming rock sockets are rock coring with rock cutting bits, and chiselling by mechanical impact. Both methods have their own merits and need skillful operators to form a proper rock socket. In general, the rock coring method will form a smoother, but intact socket surface while chiselling will form relatively rougher sockets, but these rock sockets could be more fractured due to dynamic disturbance to existing discontinuities in the bedrock. Therefore, chiselling is usually not recommended in highly fractured limestone formations to prevent the risk of further fracturing the rock mass.

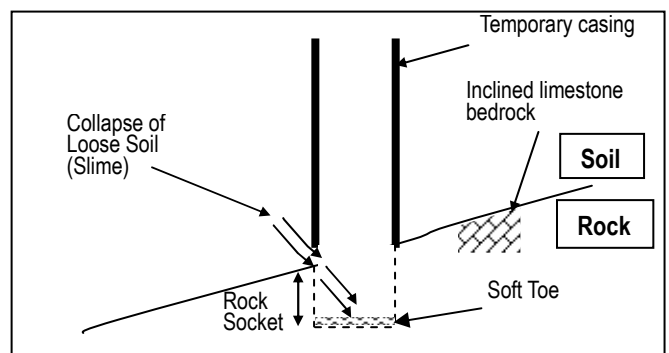
In addition, construction of bored piles in limestone areas often requires good collaboration between the design engineer and the contractor. This is due to the highly variable ground conditions which require significant input from site personnel in addition to good geotechnical design. It is recommended that the “observational approach” be

adopted for bored pile construction in limestone formation. Such an arrangement enables any unexpected geological formations and uncertainties to be detected and changes to the design can be made immediately to ensure safe and cost effective design. In order for the successful implementation of the observational approach, the designer should anticipate and identify the potential difficulties and measures that need to be carried out due to “unexpected” geological formation, such as criteria for compensation piles due to large differences in pile length caused by irregular bedrock profiles, etc. which should be in place during the design stage. Therefore, foundation construction in limestone areas is expected to involve significantly more input from the designer during the construction stage as compared to other less complicated geological formations.

In Malaysia, construction method for bored piles in limestone areas is also modified to ensure proper formation of the piles. Figure 13 shows a modified rock coring tool used for bored pile construction in limestone areas. Such a tool enables the casing to penetrate (reamed) into to the required rock socket length and thus prevents problems such as the collapse of loose soil (slime) surrounding the bored hole normally associated with the construction of rock socketed piles as illustrated in Figure 14.

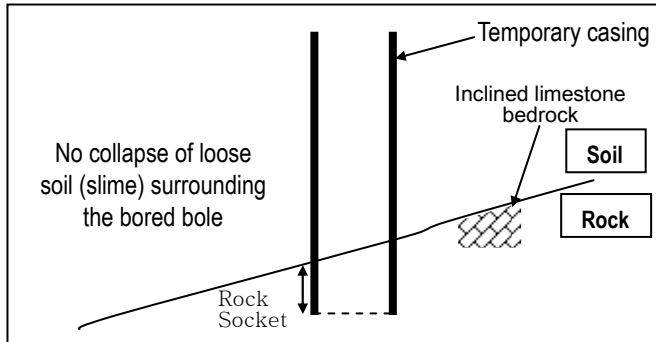


**Fig. 13** Modified rock coring tool for bored pile construction in limestone areas.



**Fig. 14** Collapse of loose soil (slime) surrounding the bored hole (Tan & Chow, 2006).

Figure 15 illustrates the performance of the modified coring tool in preventing the above problem at the interface between rock and soil by coring through to the required socket depth together with the casing. Conventional method of construction, where the temporary casing is installed using a vibro-hammer, is unable to penetrate into the rock layer and thus causes situations such as those shown in Figure 14 and also loss of concrete during concreting of the pile.



**Fig. 15** Performance of modified coring tool.

## 2.2 Micropile in Limestone Area

Micropiles in limestone areas are usually designed as rock socketed piles in the limestone bedrock to carry either compression load or tension load. All micropiles are designed to transfer load through the shaft friction, and end bearing at the pile tip is generally negligible due to its small base area. In Malaysia, the design of micropiles is usually based on British Standards such as BS449, BS8081, BS8110 and BS8004 as there is no specific design standard for micropiles. References are also made to other publications such as the Federal Highway Administration, FHWA manual titled "Micropile Design and Construction Guidelines" (FHWA, 2000), Bruce et al. (1997), Gue & Liew (1998) and Juran et al. (1999).

The design rock socket friction can be estimated following the procedures outlined above for bored piles. Alternatively, preliminary estimates can also be made with reference to Table 24, BS8081: 1989 where summaries of rock/grout bond values which have been employed in practice for ground anchors are presented.

In this paper, only specific design aspects related to micropiles in limestone area are discussed. For general design aspects of micropiles, reference can be made to publications cited earlier and also by Gue & Liew (1998) for Malaysian practice.

One aspect of micropile design which is often overlooked is the strain compatibility between the unconfined grout and the reinforcements. In view of the relatively high design axial stress (50% of the yield stress of the reinforcement) usually adopted for the reinforcement, the primary load carrying element in micropiles is the reinforcement instead of grout. In the load transfer stratum, the grout in the annulus between the reinforcement and founding stratum, as

a bonding medium, plays an important role in transferring axial load from the reinforcement to the founding stratum. Therefore, the grout must be in good integrity and be intact to transfer the load effectively. If the grout fails in crushing due to excessive compressive stress before the reinforcement reaches the design axial stress, progressive debonding at the grout/reinforcement interface is then expected, hence increasing the elastic deformation at the debonded pile segment and reducing the load transfer efficiency at the grout/soil interface. This is particularly critical for micropiles with bar reinforcement under compressive load as the bar reinforcement will buckle due to insufficient confinement by the crushed grout.

Although the compressive strain limit for concrete is well recognised to range from  $2.0 \times 10^{-3}$  to  $3.5 \times 10^{-3}$  (e.g. AASHTO section 8.16.2.3 limits the maximum usable concrete compression strain to  $3.0 \times 10^{-3}$  and BS8110 adopts a failure strain of  $3.5 \times 10^{-3}$ ), it is believed that yielding of grout at lower compressive strain may occur. Two failure mechanisms can be expected if the strain of the reinforcement reaches the yielding strain limit of the grout. First is the crushing of grout body under excessive compression. Second is the yielding at reinforcement/grout interface. Gue & Liew (1998) are of the opinion that the second failure mechanism will likely happen, because the adhesion of most normal material is always lower than its cohesion, which is governed by its grout strength. Once the overstressing occurs, the yielding of the grout/reinforcement interface will propagate to a deeper depth until the stress level in the grout under lateral confinement drops below the limit. The yielding of the interface is expected to be less significant for micropiles socketed into sound rock. This is because the confinement provided by the sound rock and the axial strain in the micropile attenuates very rapidly with depth at the rock socket. The design implications of interface yielding are elastic shortening, reduction of effective composite sections and unsatisfactory load transfer at the yielding portion of the pile to the ground. In the design of friction piles in soil, care has to be taken to minimise such yielding. Similar concepts are applicable to tension piles. Therefore, it is recommended to limit the strain to prevent yielding of grout. For preliminary design purposes, a strain limit of  $1.0 \times 10^{-3}$  is recommended for unconfined grout. This strain limit corresponds to the yield limit specified in BS8110: Part 1 which is given by the following equation:

$$\epsilon_{\text{yield}} = 2.4 \times 10^{-4} (f_{\text{cu}}/\gamma_m)^{0.5}$$

where

$f_{\text{cu}}$  = characteristic strength of grout

$\gamma_m$  = partial safety factor (= 1.5)

Therefore, for typical range of grout strength of  $25\text{N/mm}^2$  to  $40\text{N/mm}^2$ , the above equation would give values of  $\epsilon_{\text{yield}}$  between  $1.0 \times 10^{-3}$  to  $1.2 \times 10^{-3}$ .

An example calculation of the strain compatibility problem for micropile design is illustrated below:

Assuming:

Yield strength of steel pipe (API),  $f_y = 552,000 \text{ kPa}$

Young's modulus of steel reinforcement,  $E_s = 210 \times 10^6 \text{ kPa}$

Characteristic strength of grout,  $f_{cu} = 30,000 \text{ kPa}$

At allowable working stress of steel reinforcement (50% of yield stress), the elastic strain,  $\epsilon_s$ , on the reinforcement will be as follows:

$$\epsilon_s = \sigma_s / E_s = (0.5 \times 552,000) / (210 \times 10^6) = 1.314 \times 10^{-3}$$

For strain compatibility, the grout should have the same strain as the reinforcement and the calculated values exceed  $\epsilon_{yield}$  of the grout of  $1.0 \times 10^{-3}$  and therefore, yielding of the interface is expected.

The solutions to this problem for piles under compression are as follows:

- Reduce the pile axial stress to an acceptable strain limit of grout by downgrading the pile capacity or increasing the reinforcement.
- Use grout with higher characteristic strength and stiffness and therefore, a higher yield strain limit.
- Provide permanent steel casing to confine the grout as higher strength and stiffness are experienced in full confinement of the material. The confined state of the grout inside the casing section also allows the grout to support higher strain values without fracturing (FHWA, 2000). Based on FHWA (2000), typical value of Young's modulus for grout,  $E_{grout}$  is 23,000 MPa for unconfined grout and increases to 31,000 MPa for grout confined in a cased length. Such confined grout would be able to support higher strain values and therefore, strain limit of  $1.3 \times 10^{-3}$  is recommended for confined grout.

For micropile design in limestone area, if empty cavity or very soft slime zone is encountered, the buckling load should be considered for necessary downgrading of pile capacity in compression. The Euler formula shown below can be used to calculate the buckling load depending on the end constraints:

$$P_{cr} = \pi^2 E_p I_p / (KL)^2$$

where

$P_{cr}$  = Buckling load (kN)

$E_p$  = Young's modulus of equivalent pile section (kN/m<sup>2</sup>)

$I_p$  = Moment of inertia of equivalent pile section (m<sup>4</sup>)

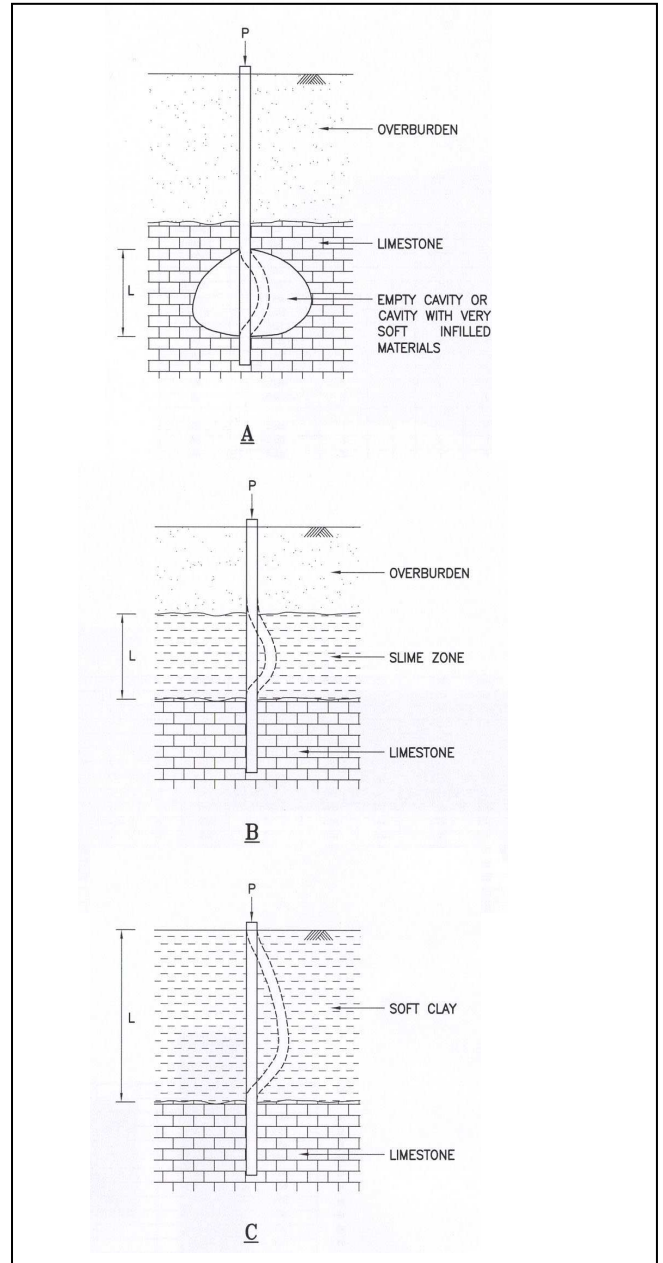
$L$  = Length of pile column without lateral support (m)

$K$  = 1.0 for pinned ends

0.25 for fixed ends (for the cases of cavity or slime zone – Cases A and B)

0.7 for one fixed end and one pinned end (for the case of soft clay – Case C)

Figure 16 shows the possible end constraints for buckling piles in different cases.



**Fig. 16** Buckling modes of micropiles (Gue & Liew 1998).

Similar to other pile foundations, the success of micropiles in limestone area also relies on the quality of installation and therefore some construction control guidelines to ensure successful pile installation are given as follows (Gue & Liew, 1998):

- As it is very difficult to determine the rock conditions for every pile, visual inspection of the rock chipping by experienced supervising personnel is useful in determining the degree of weathering, indicative rock strength, rock mass structures and/or karst features. Records of the socket penetration rate, calibrated to the borehole information and the hydraulic pressure applied on the drill shafts can provide indication of rock quality. Changes of water level or stabilising fluid

may indicate the existence of cavities, solution channels and permeable layers where excessive grout loss is anticipated. Change of hydraulic pressure or a sudden drop of drill shaft may also indicate karst features.

- b) Measures should be taken to avoid drillhole collapse by means of temporary protection casing and/or stabilising fluid.
- c) Grouting should be carried out immediately after cleaning the drillhole by flushing the drillhole with clean water.
- d) Permanent casing can be used to minimise excessive grout loss. Alternatively, the use of rapid hardening grout or compaction grout to seal the flow channel can be used.
- e) Proper connection ensuring both ends of the pipes in full contact for coupler and threaded joints and sufficient lapping of reinforcement bars is important to ensure efficient load transfer between the reinforcement. At coupling or reinforcement lapping, it is recommended to stagger the coupling or lapping to avoid weak sections.
- f) Centralisers of reinforcements are important elements to ensure adequate grout cover for the bonding of interfaces.
- g) Excessive welding on high yield steel reinforcement should be avoided as heat can alter the chemical and physical properties of the material.
- h) Grease or coating on reinforcement should be removed to ensure good bonding. However, cleaning of the debonding material at the inner surface of the pipes is very difficult.
- i) Provision of holes should be allowed at the tip of API pipe to facilitate grouting between the drillhole and the API pipe.

### 3 JACK-IN PILE

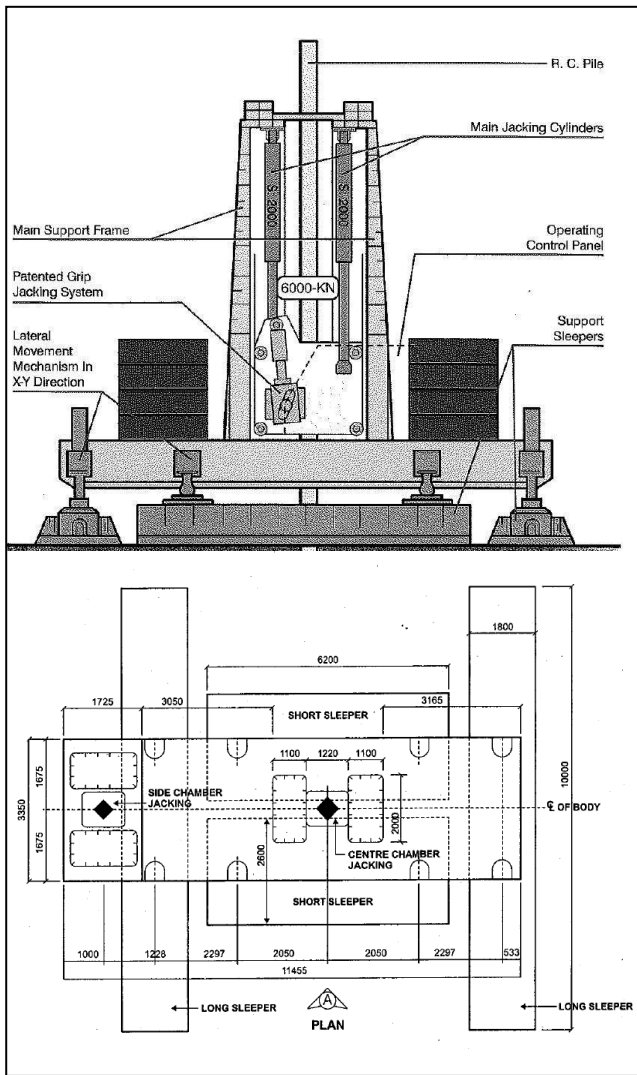
Jack-in pile foundation has been successfully adopted in Malaysia since the 1990s and currently, large diameter spun piles of up to 600mm diameter with working loads of up to 3000kN have been successfully adopted for high-rise buildings of up to 45-storeys. The popularity of jack-in pile foundation system especially for construction works in urban areas is due to their relatively lower noise and lower vibration compared to conventional piling systems such as driven piles. Jack-in pile foundation also offers advantages in terms of faster construction rates, better quality control, less pile damage and cleaner site conditions as it does not require the use of stabilizing liquid/drilling fluid typically associated with bored piles and micropiles. In practice, piles installed using the jack-in method are expected to be slightly shorter than driven piles. This is because driven piles are often driven to greater length than is truly necessary due to the uncertainties associated with their geotechnical capacity during driving. However, jack-in piles are jacked to the specified capacity and therefore, result in savings without compromising the safety, serviceability requirements and integrity of the pile foundation. However, like all available systems, jack-in piles also have their drawbacks, such as the

need for a relatively stronger platform to support large and heavy machinery and a generally larger working area to install the piles. However, the drawbacks can be managed if the designer is aware of these limitations and jack-in pile foundation systems have been successfully adopted in congested condominium developments, piling works at different platform levels with limited working space and works carried out at lower ground level associated with basement construction.

Figures 17 and 18 show typical high capacity jack-in pile machine in Malaysia and schematic of the machine respectively. Table 2 summarises some key technical data for the machines.



**Fig. 17** Typical high capacity jack-in pile machine in Malaysia.

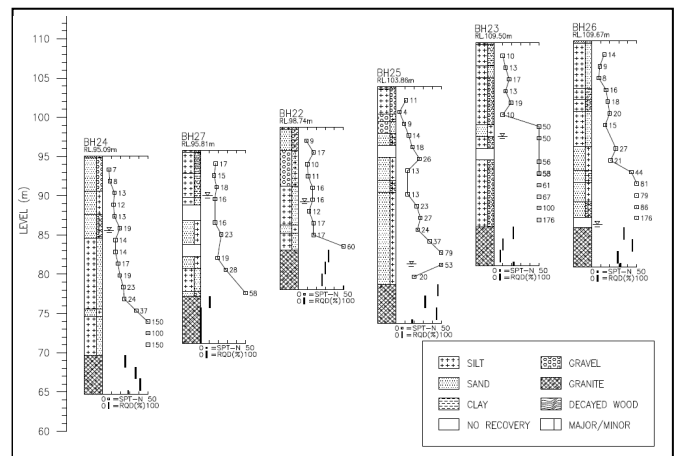


**Fig. 18** Typical schematic of high capacity jack-in pile machine.

As jack-in pile foundation system is relatively new, available data and experience on jack-in piles are still limited. As such, geotechnical design of jack-in pile is normally based on driven pile experience, which is expected to be conservative. Recent experiences by the Authors, as well as other research findings, have shown that geotechnical capacity of jack-in piles is expected to be higher compared to driven piles. Therefore, based on the Authors' experiences (Chow & Tan, 2009) a more reliable indicator of the ultimate capacity of jack-in pile is based on the maximum jack-in force imposed onto the pile during installation. Some of the experiences gained by the Authors in the application of jack-in piles based on case histories of four sites which are reported in Chow & Tan, 2009 are briefly discussed in this paper. Some details of the four sites are as follows:

- Site A – 31-storey condominium development
- Site B – 45-storey condominium development
- Site C – 40 to 43-storey condominium development
- Site D – 15-storey condominium development

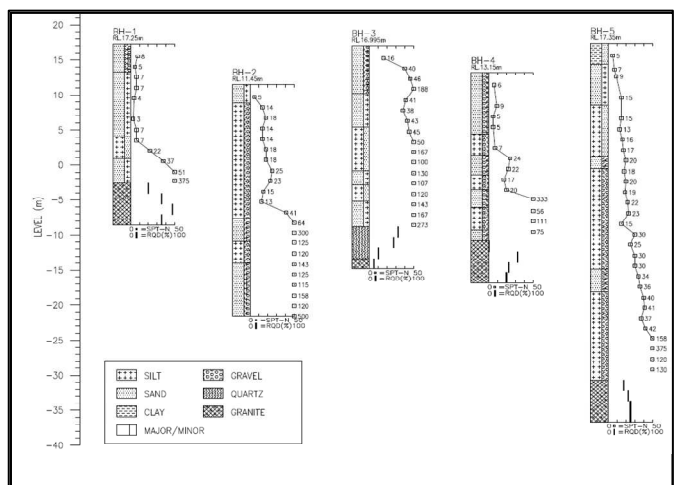
All four sites are located in weathered granite formation with overburden materials mainly consisting of silty SAND/sandy SILT with variable thicknesses. Typical borehole profiles for the sites are shown in Figures 19 and 20.



**Fig. 19** Borehole profiles at Site B.

**Table 2** Key technical data of high capacity jack-in pile machines.

ITEM	TECHNICAL DATA
Maximum Jacking Force	6000kN
Applicable Spun Pile Diameter	250mm to 600mm
Applicable RC Square Pile Size	250mm to 400mm
Self Weight (Excluding counterweight)	1800kN to 2000kN
Overall dimension in meter (Length x Width x Height)	11.1 x 10.0 x 9.1 13.55 x 12.0 x 7.44
Minimum clearance required for piling works (Centre jacking)	5.5m to 6.9m
Bearing pressure on sleeper	Up to 175kN/m <sup>2</sup>



**Fig. 20** Borehole profiles at Site D.

Details of the jack-in pile adopted and tested for the four sites are summarised below:

a) Site A

PILE TYPE	WORKING LOAD	TERMINATION CRITERIA*
φ450mm spun pile (100mm thk)	1520kN	Jacked to 2.5 times working load with holding time of 30 seconds
φ500mm spun pile (110mm thk)	2300kN	Jacked to 2.0 times working load with holding time of 30 seconds

b) Site B

PILE TYPE	WORKING LOAD	TERMINATION CRITERIA*
φ450mm spun pile (80mm thk)	1600kN	Jacked to 2.1 times working load with holding time of 60 seconds
φ500mm spun pile (90mm thk)	2100kN	
φ600mm spun pile (100mm thk)	2800kN	

c) Site C

PILE TYPE	WORKING LOAD	TERMINATION CRITERIA*
φ450mm spun pile (100mm thk)	1900kN	Jacked to 2.0 times working load with holding time of 30 seconds
φ500mm spun pile (110mm thk)	2300kN	
φ600mm spun pile (110mm thk)	3000kN	

d) Site D

PILE TYPE	WORKING LOAD	TERMINATION CRITERIA*
φ400mm spun pile (100mm thk)	1700kN	Jacked to 2.0 times working load with holding time of 30 seconds
φ500mm spun pile (110mm thk)	2300kN	
φ600mm spun pile (110mm thk)	3000kN	

\*The maximum jack-in pressure with holding time of 30 seconds is carried out for a minimum of two (2) cycles.

*Note: It can be observed that different termination criteria were adopted for the four different sites with maximum jack-in pressure ranging from 2.0 to 2.5 and holding time varying from 30-seconds to 60-seconds. The reasons behind this is due to technical research carried out by the Authors to find the most optimum maximum jack-in pressure and to satisfy other parties (e.g. Clients, Structural Engineers, etc.) who are not familiar with the relatively new jack-in pile foundation system. As such, sometimes more conservative maximum jack-in pressure and holding time was adopted for certain projects. Generally, maximum jack-in pressure to 2.0 times working load with a holding time of 30 seconds is sufficient (2 cycles). The implication of the difference in maximum jack-in pressure and holding time is not expected to affect the findings in this paper.*

Results of the pile load tests are summarised in Table 3. All the piles selected for testing at the above four sites passed with settlement within allowable limits.

**Table 3** Summary of pile load test results.

Pile Diameter (mm)	Pile Length (m)	Settlement (mm)		Remarks
		Working Load	2*Working Load	
<b>Site A</b>				
450*	10.5	6.36	12.89	-
500	37.0	4.53	11.89	-
500*	20.6	9.23	20.46	20m preboring
<b>Site B</b>				
450	12.0	3.04	6.96	-
500	17.7	7.82	17.81	-
500	22.6	5.39	12.77	-
500	9.5	5.41	15.03	-
500*	6.5	8.32	19.73	-
600	17.7	4.82	12.16	-
600*	20.7	5.57	13.05	-
600	14.5	9.88	21.28	-
<b>Site C</b>				
450	27.6	8.88	18.21	-
450*	32.5	6.72	15.93	-
500	24.7	8.85	22.22	Instrumented (PTP-1)
600	27.0	8.62	17.67	-
600	17.5	7.35	16.37	-
600	23.0	7.99	20.75	Instrumented (PTP-2)
600*	21.4	7.37	17.30	Instrumented (PTP-3)
<b>Site D</b>				
400	7.5	9.23	19.99	-
500*	16.5	6.41	21.83	-
600*	34.8	8.48	16.76	Instrumented (PTP-1) Pile tested up till 2.5*WL. Settlement at 2.5*WL: 23.84mm. Residual settlement after unloading from 2.5*WL: 5.48mm.
600	25.5	7.46	15.38	Instrumented (PTP-2) Pile tested up till 2.5*WL. Settlement at 2.5*WL: 21.90mm. Residual settlement after unloading from 2.5*WL: 6.33mm.

\*Plots of load-settlement results shown in Figures 21 to 24.

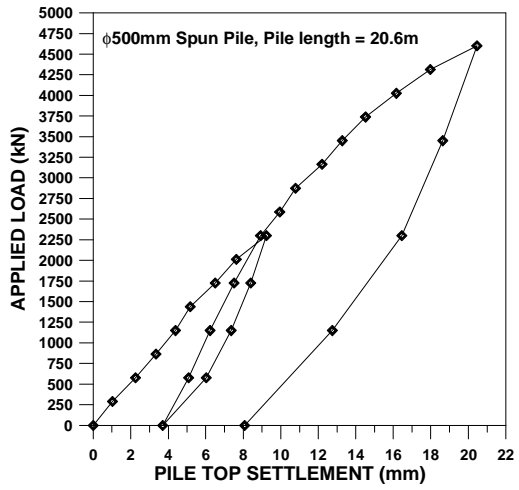
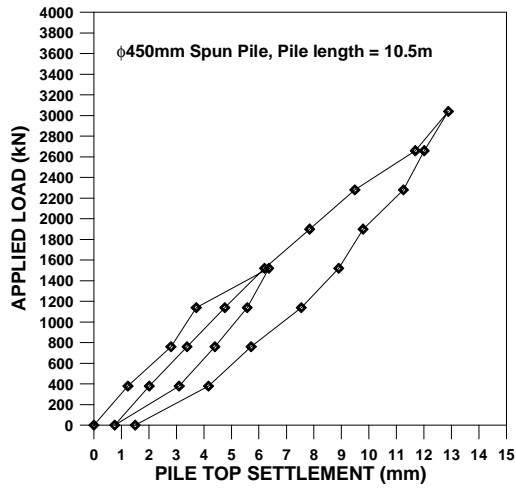


Fig. 21 Load-settlement results of pile load test at Site A.

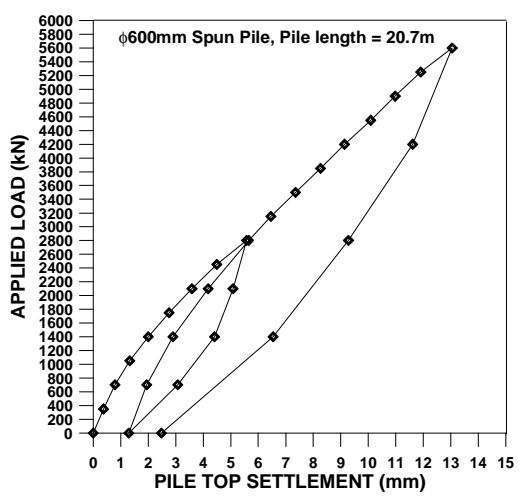
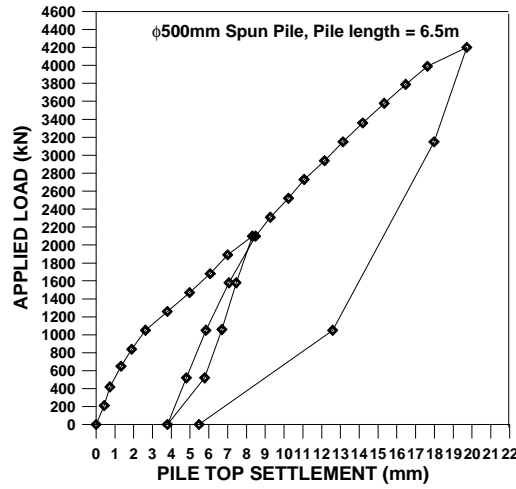


Fig. 22 Load-settlement results of pile load test at Site B.

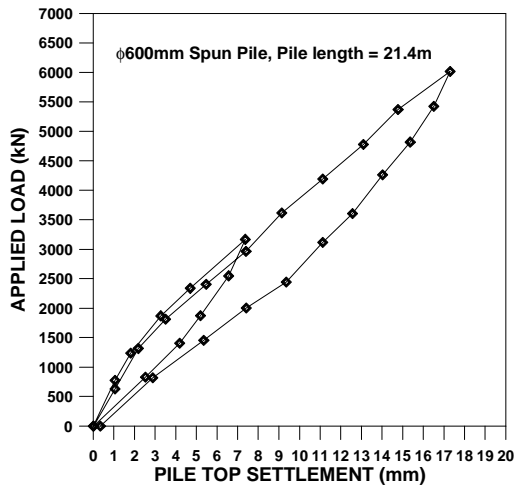
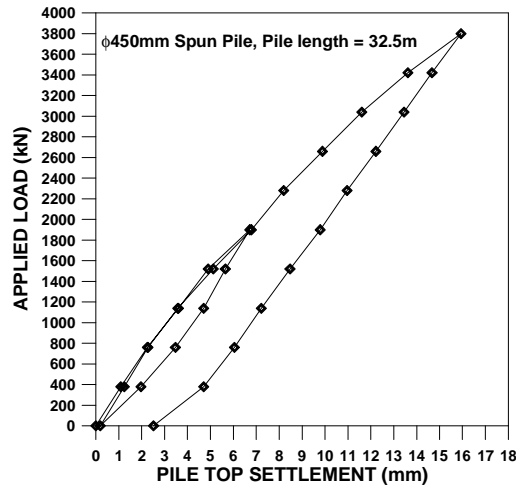


Fig. 23 Load-settlement results of pile load test at Site C.

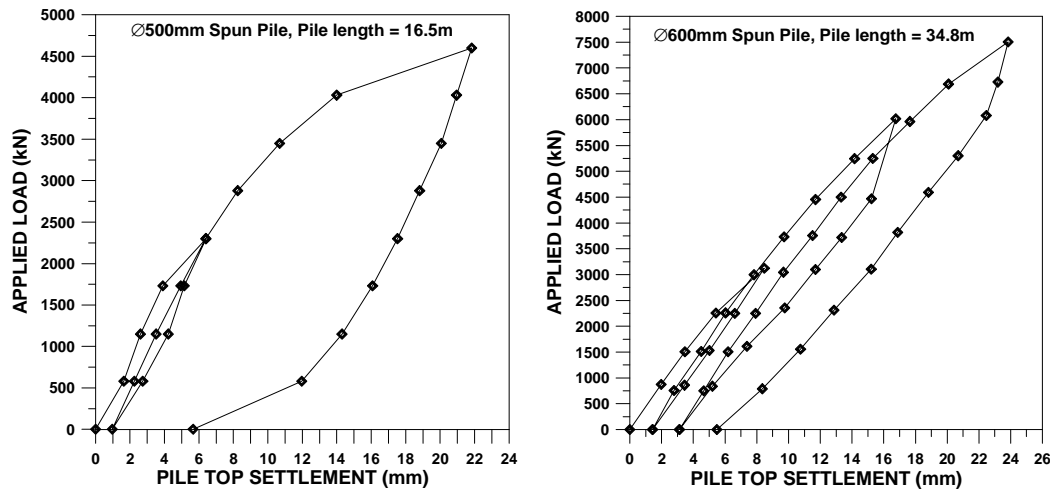


Fig. 24 Load-settlement results of pile load test at Site D.

From the above pile load test results, the following is observed:

- Pile performance is satisfactory for pile length as short as 6.5m with settlement at working load and two times working load of 8.32mm and 19.73mm respectively.
- Pile performance is satisfactory for piles where preboring has been carried out. This demonstrates the validity of the assumption that the geotechnical capacity of the pile is a function of the jack-in force during pile installation.
- The termination criterion adopted of jacking to two times of working load (WL) with holding time of 30 seconds is adequate. In fact, from the load test results (Figures 21 to 24), there is room for possible optimization, as the piles can support up to two times working load without showing signs of plunging failure. Two of the piles tested up to 2.5\*WL in Site D also demonstrate that the geotechnical capacity of the pile is more than 2.5\*WL as the residual settlement after unloading from the maximum test load is relatively small (5.48mm and 6.33mm respectively).

Based on the Authors experiences, the recommended termination criterion for jack-in piles in weathered granite formation are as follows:

“The termination criterion is to jack the pile to 2.0 times of the design load for a minimum of two cycles. The corresponding pressure has to be held for minimum 30 seconds with settlement not exceeding 2mm or unless otherwise specified by the Engineer.”

The adequacy of the proposed termination criterion in weathered granite formation has been proven adequate as illustrated in the case histories above. However, questions still arise with regards to the adequacy of maintaining the jack-in pressure for the relatively short duration of 30 seconds only where long-term settlement of the pile cannot be verified. This is especially so when practices in some other countries require the jack-in pressure to be maintained for as

long as 15 minutes. However, it should be noted that the objective of the termination criterion is to ensure the pile is jacked to the required soil depth in order to achieve the required geotechnical capacity and is not for settlement verification. This is similar to installation of driven piles where the termination (or “set”) criterion of piles is determined to ensure adequate geotechnical capacity and long-term settlement of the piles definitely cannot be directly assessed during pile driving. For bored piles, verification of pile capacity and settlement characteristics depend solely on load tests.

The designer is still responsible for assessing the adequacy of the installed pile length based on available subsurface investigation (SI) information. For example, it is not adequate for piles where significant proportion of the pile capacity consists of end-bearing to have the required termination criterion on a thin layer of intermediate hard layer/boulder followed by a soft soil below. The pile should terminate in a competent stratum to ensure the load-carrying capacity of the pile is adequate for long-term within acceptable serviceability limits. This is similar to conventional driven pile design practice.

Therefore, similar to conventional pile design, the termination criterion for jack-in piles should be subjected to verification via a maintained load test to ensure adequate geotechnical capacity within acceptable serviceability limits. However, jack-in pile offers considerable advantages over conventional driven and bored pile system as shown in Table 4.

It can be seen from Table 4 that jack-in pile foundation system offers advantages compared to other piling systems as every pile installed is being verified that it can sustain at least two times the pile working load without suffering plunging (geotechnical) failure. This is supported by research findings of Deeks, White & Bolton (2005) and case histories discussed earlier. Driven piles can only offer indirect verification which depends on a lot of external factors such as hammer performance, drop height, etc. while

no such benefits are offered by bored piles. Therefore, the risks of inadequate geotechnical capacity for jack-in piles are lower as each working piles are subjected to “static” load tests with shorter holding time.

A proper selection of suitable RC spun piles for jack-in pile application is also important to minimise pile damage. Experiences have indicated that slightly thicker spun piles are required to withstand the high gripping force during installation. The required thickness may differ if different gripping system is employed.

The approach of using settlement reducing piles can be further divided into two categories of application:

- a) Local deformation
- b) Overall deformation

The use of settlement reducing piles to control local deformation is illustrated in Figure 26 while the control of overall deformation is similar to the concept illustrated in Figure 25 and further demonstrated in Figure 27.

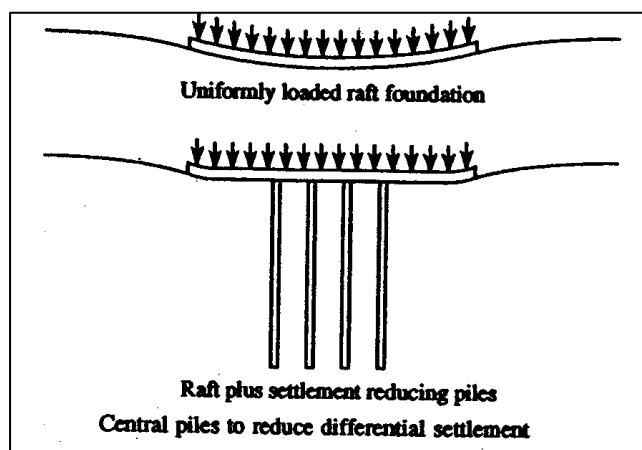
**Table 4** Comparison of different types of piling systems.

	<b>JACK-IN PILE</b>	<b>DRIVEN PILE</b>	<b>BORED PILE</b>
<b>Loading rate during pile installation</b>	Slow	Very fast	N.A.
<b>Termination criteria</b>	Static (pseudo) load imposed onto pile head	Dynamic load imposed onto pile head	Based on SI information
<b>Variables affecting efficiency of load transfer during pile installation</b>	<ol style="list-style-type: none"> <li>1. Hydraulic system of jacks</li> <li>2. Calibration of pressure gauge</li> <li>3. Gripping system of piling machine</li> </ol>	<ol style="list-style-type: none"> <li>1. Efficiency of hammer, helmet, etc.</li> <li>2. Hammer drop height</li> <li>3. Cushion properties</li> <li>4. Eccentricity of pile/hammer</li> </ol>	N.A.
<b>Verification of geotechnical capacity during installation</b>	Relatively straightforward as loading rate is slow	Indirect verification based on dynamic analysis. Often unreliable.	N.A.
<b>Probability of pile damage during installation</b>	Low	High	Depends on workmanship

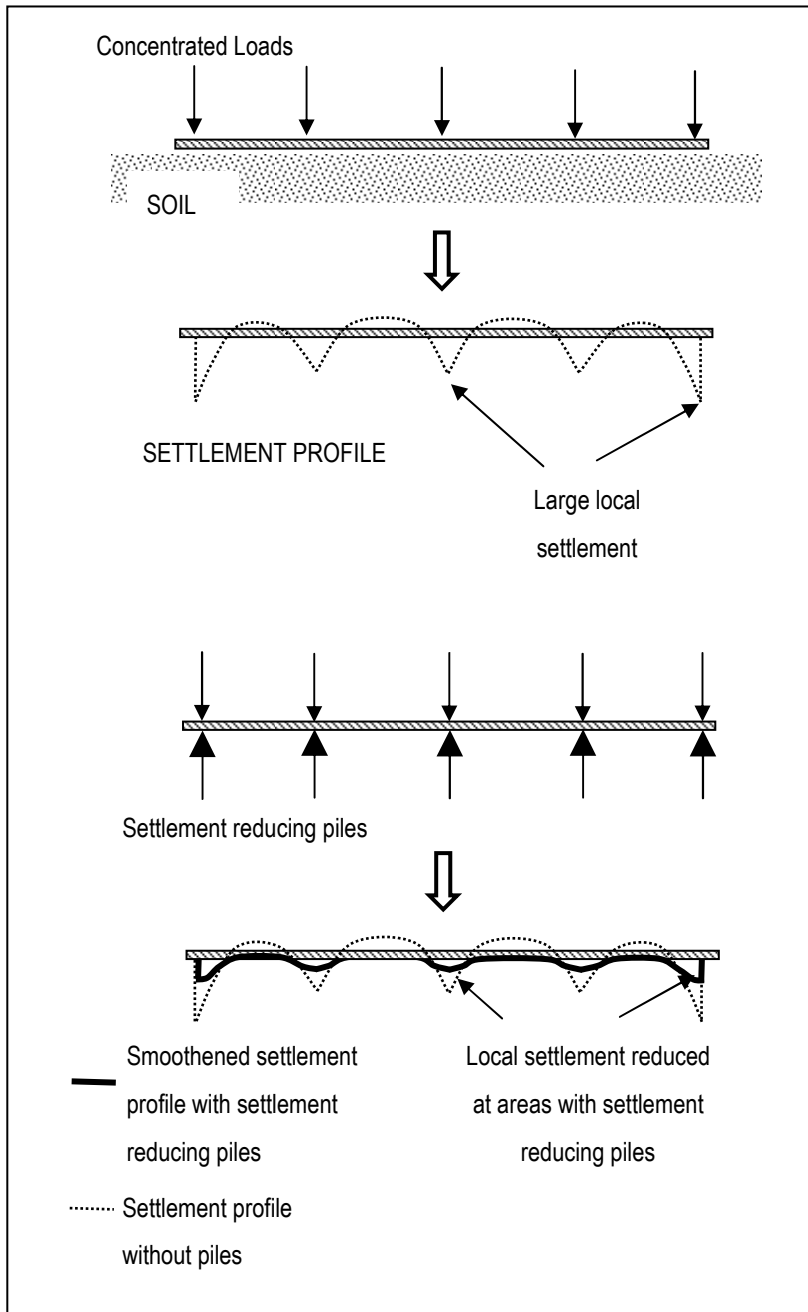
#### 4 PILED RAFT FOUNDATION SYSTEM

Like most major Asian countries, the locations of major cities of Malaysia are close to major rivers or at river mouths. As such, design and construction of civil engineering works at such areas with presence of thick deposits of alluvial soft clay poses significant challenge to geotechnical engineers. Recent innovations in the use of piled raft foundation system in soft clay include the concept of short-friction piles for low-rise structures (Tan et al., 2004) and the use of piled raft with different pile lengths (Tan et al., 2005 and Liew et al., 2002).

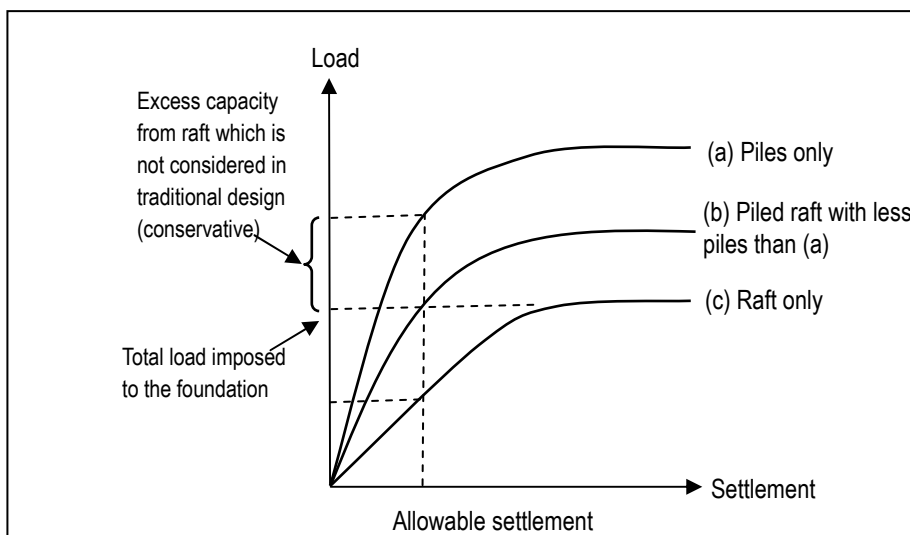
The general concept of piled raft using settlement reducing piles is illustrated in Figure 25. The method is first proposed by Burland et al. (1977) and subsequently, various case histories have been reported (e.g. Love, 2003, Yamashita et al., 1994 and Burland & Kalra, 1986). For the idealized condition of uniform loading, the settlement profile of the raft foundation is of ‘bowl’ shape where the settlement is the largest in the centre and smallest at the edge. Settlement reducing piles are therefore introduced at the centre of the raft to reduce raft settlement at the centre and thus reduce differential settlement.



**Fig. 25** Concept of settlement reducing piles (Randolph, 1994).



**Fig. 26** Settlement reducing piles to control local deformation.



**Fig. 27** Concept of piled raft.

It can be seen then that with piles strategically located at areas of concentrated loadings or at areas with the largest settlement, the differential settlement of the foundation can be controlled to prevent serviceability problems such as cracking, etc. In addition, it must be pointed out that the use of settlement reducing piles would also reduce the stresses on the structural raft. The use of piles to reduce stresses on the structural raft can also be referred to as “stress reducing piles” (Burland & Kalra, 1986).

The benefits of considering both raft and piles in the assessment of the foundation system are clearly illustrated in Figure 27. Traditionally, piles are often introduced when the overall settlement of the raft is unacceptable for the particular usage of a structure. However, by assuming that the loads are resisted entirely by the piles only (raft ignored) would result in unduly conservative design where the settlement is reduced significantly smaller than necessary. In addition, significantly higher number and total length of piles are required when the load resisting contribution of the raft is ignored. This is significant especially for large pile group with large spacing in soft ground with a filled platform where capacity of pile designed conventionally have to be downgraded for negative skin friction.

#### 4.1 Piled Raft System for Low-Rise Buildings (Less than 3-storeys high)

The piled raft system for low-rise buildings is generally based on the concept of settlement reducing piles to control local deformation where piles of single length are strategically located beneath concentrated loads. The design approach adopted generally follows the recommendations of Poulos (2001) where four circumstances in which a pile is provided beneath a concentrated load (i.e. column or wall):

- a) Condition 1: if the maximum moment in the structural member below the column exceeds the allowable value for the structural member.
- b) Condition 2: if the maximum shear in the structural member below the column exceeds the allowable value for the structural member.
- c) Condition 3: if the maximum contact pressure below the foundation exceeds the allowable design value for the soil.
- d) Condition 4: if the local settlement below the column exceeds the allowable value.

Poulos (2001) original recommendations as summarised above are derived for stiff/dense soil. However, in this paper, the above approach has been extended for soft ground with some adjustments.

In order to adopt the concept of settlement reducing piles, the foundation raft must be able to provide adequate bearing capacity in the first place and the piles are solely introduced to control differential settlements within allowable limits of angular distortion, and also to reduce the stresses on the structural member. At areas of concentrated columns and walls loads, large contact pressure is induced on the soft ground which can cause excessive local settlement leading

to cracks on buildings. Therefore, Conditions 3 and 4 arise which necessitate the introduction of settlement reducing piles. The settlement reducing piles are designed as friction piles and this eliminate the risk of structural failure or inadequacy of piles due to negative skin friction. The structural member of the foundation system is then determined based on factors such as the architectural layout, arrangement of columns and walls, etc in order to provide the required rigidity to distribute the superstructure loads. Usually for low-rise buildings, the structural member of the foundation system consists of combination of strips and raft. This system is adopted to minimize the thickness of the raft for maximum economic benefits while not sacrificing the required rigidity. Therefore, the strips serve the dual purpose of providing the required rigidity to the foundation system and also as ‘pilecaps’ to distribute the column and wall loads to the piles. With the strips located directly beneath the columns and walls and subsequently designed to resist the stresses induced by the columns and walls loads with the settlement reducing piles in place, Conditions 1 and 2, which are governed by structural considerations, are no longer critical.

The locations of the settlement reducing piles as determined based on Conditions 3 and 4 mainly concentrate at column locations and along the span of line loads (i.e. walls). With the piling layout confirmed and framing of the strip-raft completed, detailed analyses of the foundation system to determine the stresses induced on the structural members are carried out for subsequent structural design. This can be carried out using commercially available structural analysis software.

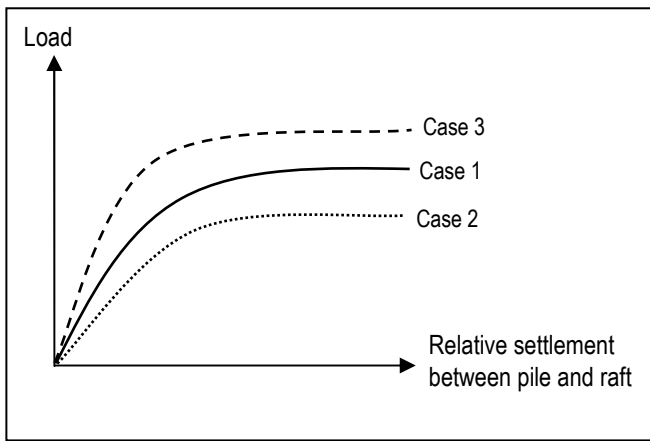
However, due to the limitations of structural analysis software where supports are usually modelled using uncoupled spring constants or Winkler foundations, it is necessary to determine the appropriate spring constants to account for the actual behaviour of the foundation system. The limitations of the Winkler foundations as highlighted by Poulos (2000) must be clearly understood in order to produce meaningful analysis results. The detailed analyses carried out can be broadly divided into two categories:

- a) Local stresses at locations of concentrated loads
- b) Overall stresses for the whole block of the houses

Analysis to determine the local stresses are further divided into three different cases (Tan et al., 2004):

- a) Case 1: Pile performance as per prediction
- b) Case 2: Pile performance is lower than prediction (undercapacity)
- c) Case 3: Pile performance is better than prediction (overcapacity)

The load-settlement response of the pile given by the three cases above is shown in Figure 28.

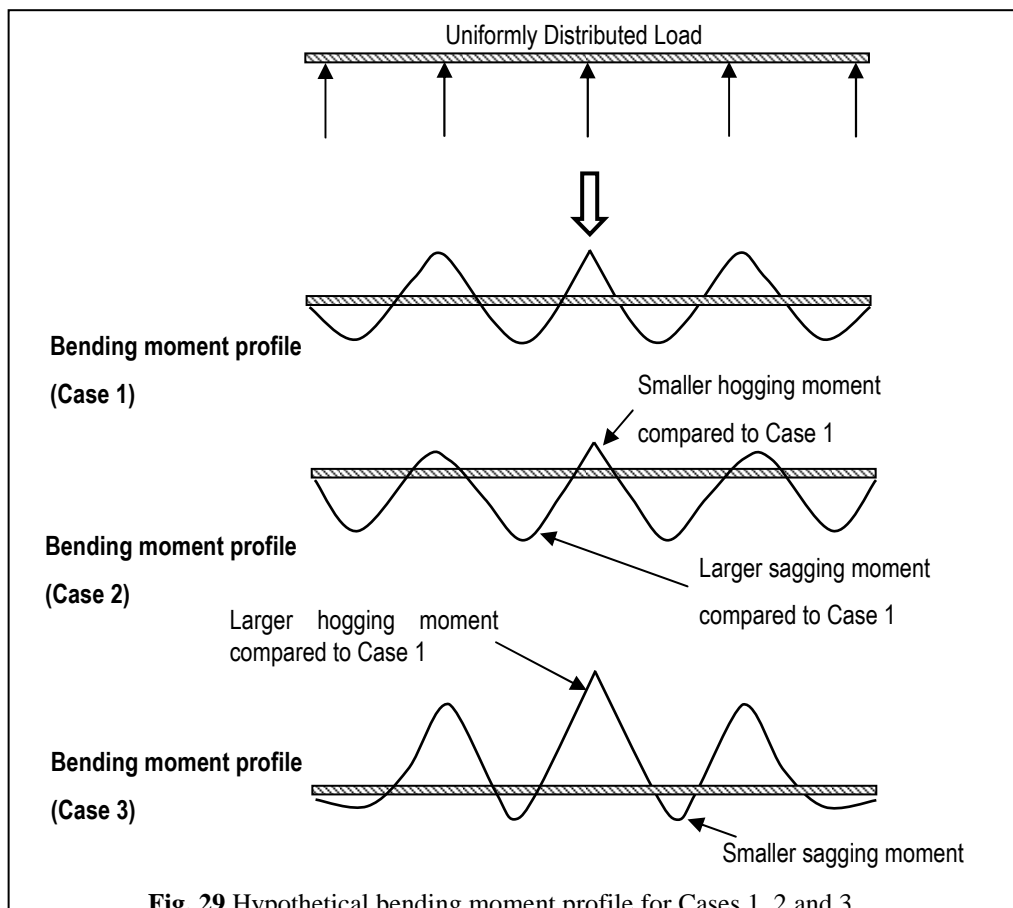


**Fig. 28** Load-settlement response for Cases 1, 2 and 3.

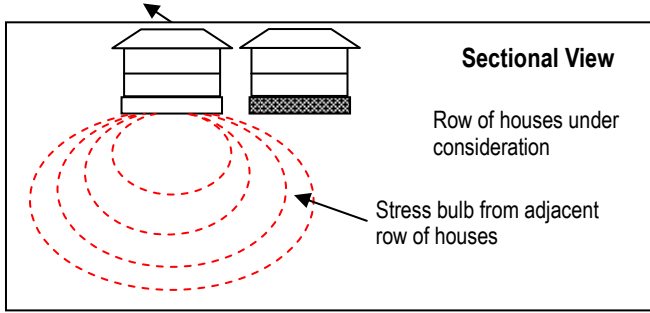
The three cases cater for possible variations in the subsoil properties and pile installation procedures resulting in different values of relative pile stiffness and soil stiffness beneath the raft. The variations of the stiffness would affect the stresses generated in the structural members and need to be taken into consideration. A hypothetical example as illustrated in Figure 29 shows that different magnitudes of hogging and sagging moments are induced in the structural member due to different values of relative pile-soil stiffness of Cases 1, 2 and 3. The design of the structural member to cater for localised stresses, therefore, has to be based on the envelope of stresses (bending moment and shear) for the three cases. Similar design approach using settlement reducing piles has also been adopted by Love (2003) for stiffer materials.

With the local stresses being catered for by the three cases (Cases 1, 2 and 3), the overall stresses for the whole block of the houses needs to be analysed based on the overall settlement profile of the block of houses. As highlighted by Terzaghi (1955) and Poulos (2000), the Winkler system has its limitations in that it is only able to furnish values of local stresses. Therefore, in order to cater for overall stresses on the whole block of the houses, additional settlement analyses are carried out to determine the settlement profile for subsequent determination of spring stiffness for the piles and soil. The settlement analysis can be carried out based on Terzaghi's 1-dimensional consolidation theory and the stress distribution is based on Boussinesq's theory. The raft can be assumed to be truly flexible as the raft is relatively "thin" compared to its size (area) which is on the conservative side for design. The settlement analysis must also take into consideration the effect of adjacent rows of houses as shown in Figures 30 and 31.

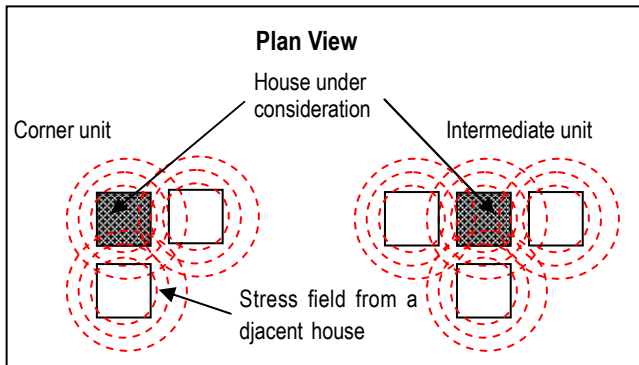
Typical settlement profiles obtained from the settlement analyses are shown in Figures 32, 33 and 34 respectively. The settlement profile are subsequently used to determine the spring stiffness (value of load/settlement) for the pile and soil support in order to simulate a similar settlement profile giving the overall stresses on the whole block of houses. The figures show the effect of load from adjacent block of houses in increasing the settlement and hence differential settlement. Therefore, particular care should be given to the design of the foundation system especially at the corner of the blocks and at areas facing another block of houses, as the differential settlement and bending moment are the largest at those areas.



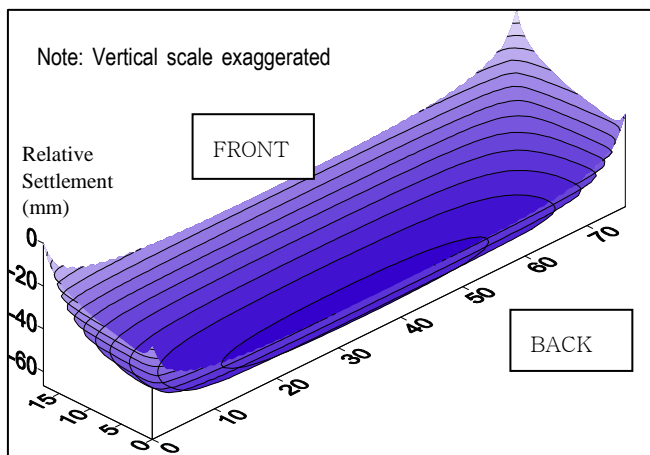
**Fig. 29** Hypothetical bending moment profile for Cases 1, 2 and 3.



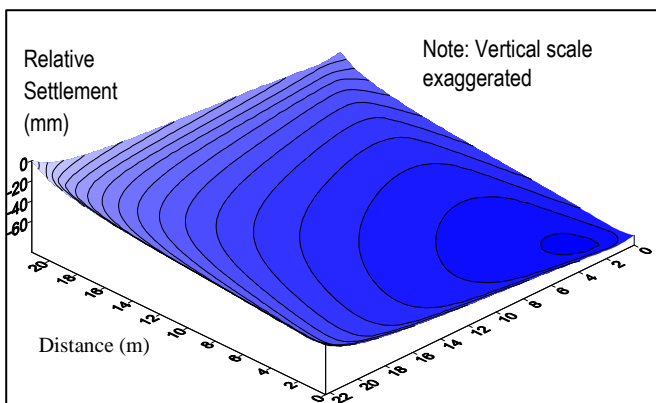
**Fig. 30** Effect of adjacent houses on settlement (terrace house).



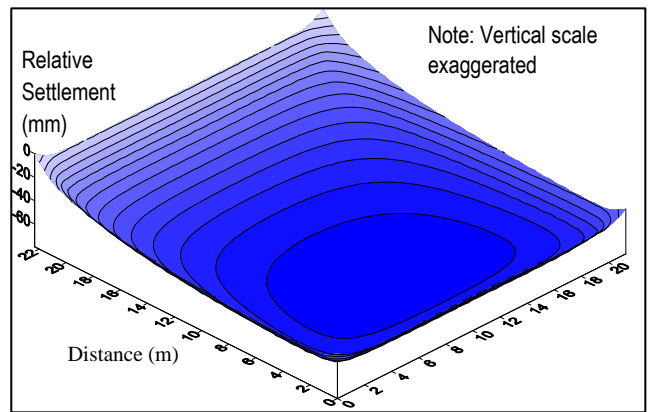
**Fig. 31** Effect of adjacent houses on settlement (semi-detached house).



**Fig. 32** Settlement profile for terrace house.



**Fig. 33** Settlement profile semi-detached house (corner unit).



**Fig. 34** Settlement profile semi-detached house (intermediate unit).

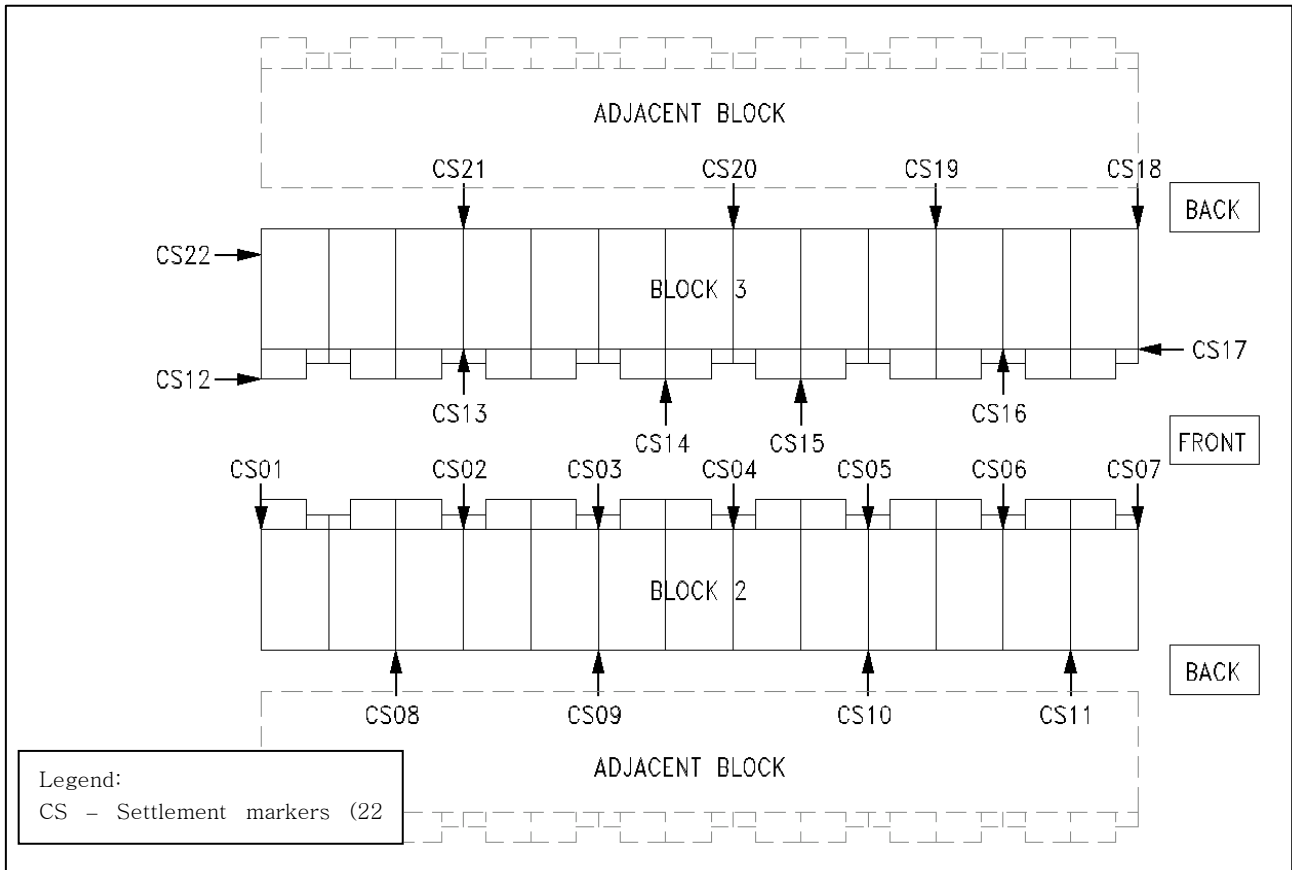
Instrumentation results reported by Tan et al. (2004) have confirmed the validity of the above approach where settlement monitoring has demonstrated the adequacy of the foundation system and also show the effect of load from adjacent structures influencing the settlement profile. Figure 35 shows the locations settlement markers while Figures 36 and 37 show the settlement monitoring results.

#### 4.2 Piled Raft System for Medium-Rise Buildings (3 to 5-storeys high)

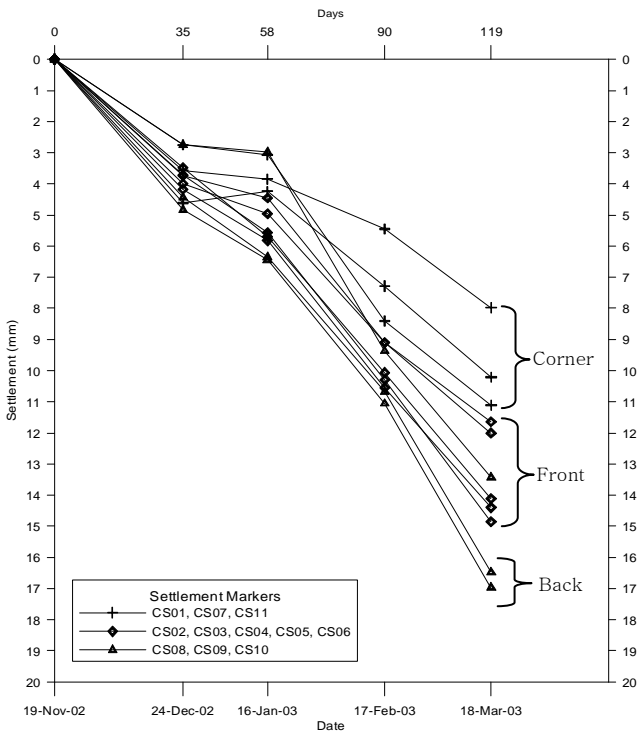
For medium-rise buildings, due to relatively higher loads imposed onto the foundation, the piled raft system consists of piles with varying pile length interconnected with a rigid system of strip-raft. This approach is adopted due to the larger overall settlement expected as compared to low-rise buildings. This will result in a more pronounced 'bowl' shaped settlement profile. Therefore, piles of varying length with the longest piles in the middle and progressively shorter piles towards the edge are adopted as shown in Figure 38 to reduce differential settlement.

The interaction between the pile-soil-structure (strip-raft) is carried out iteratively using pile interaction software (e.g. PIGLET, PIGEON) and structural analysis software (e.g. SAFE). The convergence criteria adopted for the iterative analysis is set at  $\pm 10\%$  variation of pile reactions from previous analysis. The proposed approach of using the pile interaction and structural analysis software iteratively arises due to limitations of the respective commercial software in modelling pile-soil-structure interaction as follow:

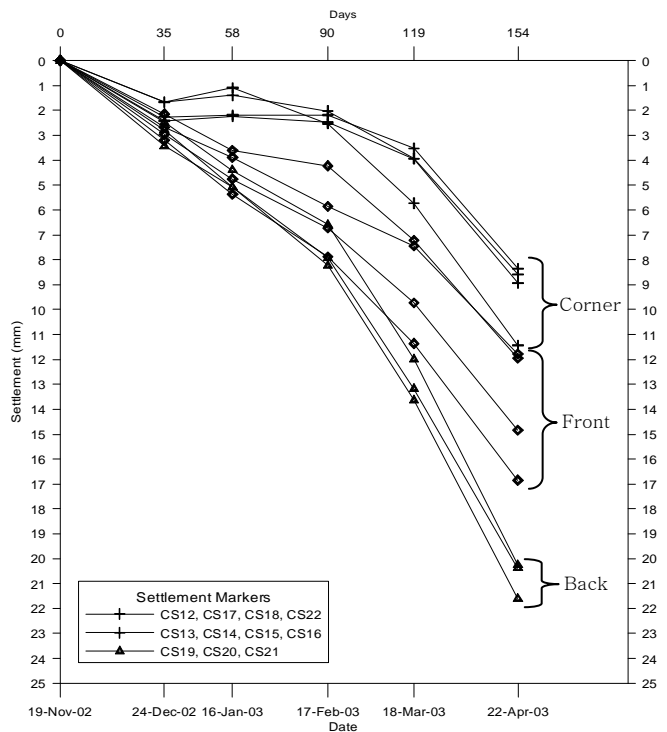
- a) General pile interaction software
  - Limitations:
    - i. Unable to model strip-raft.
    - ii. Unable to cater for random locations of column and wall loads (only caters for point load at centre of strip-raft, uniformly distributed load over the entire foundation or point load on each pile).
  - Applications:
    - i. To model pile-soil interaction which cannot be modelled by general structural analysis software.



**Fig. 35** Location of settlement markers.



**Fig. 36** Settlement monitoring results for Block 2.



**Fig. 37** Settlement monitoring results for Block 3.

b) General structural analysis software

- Limitations:

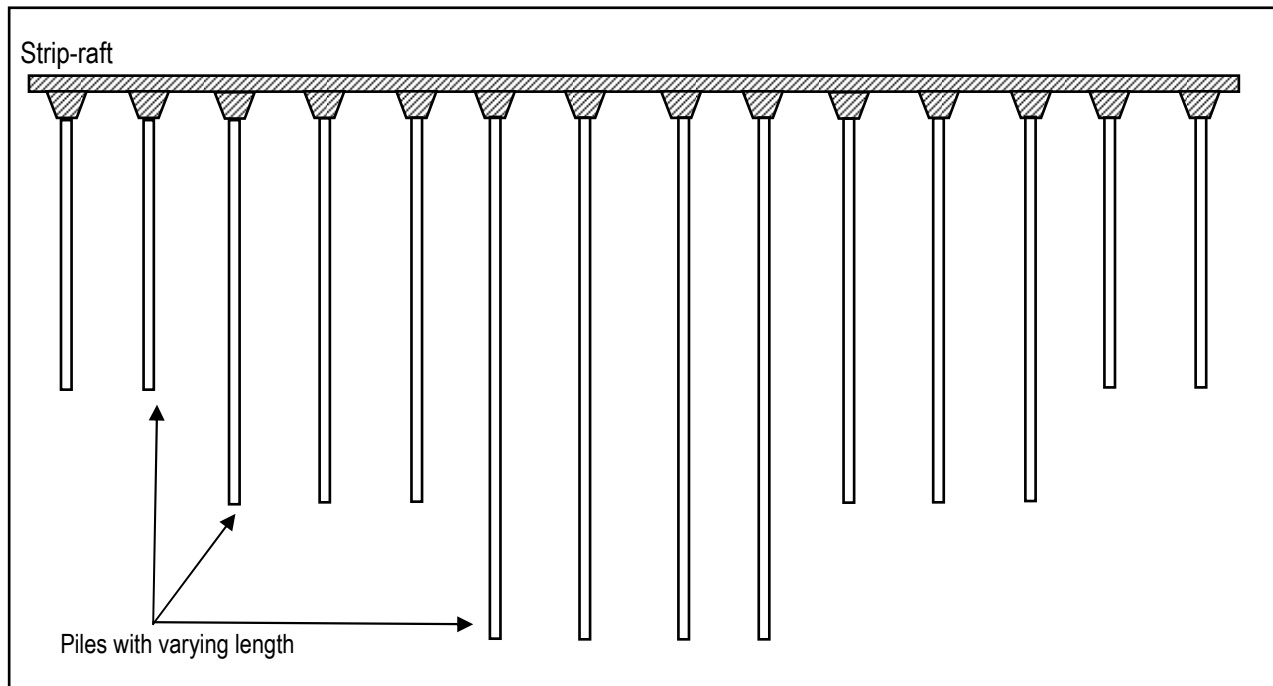
- i. General structural analysis software usually adopts Winkler model for soil and uncoupled spring constants for piles where interaction between piles and soil cannot be modelled.

- Applications:

- i. To model the strip-raft and its effect on the pile-soil interaction.
- ii. To cater for random locations of column and wall loads.
- iii. To determine stresses on the strip-raft for design.

PIGLET is derived for piles of uniform length. Therefore, the original equation proposed by Randolph & Wroth (1979) is revisited by the Authors in order to derive a solution for piles with varying pile length.

The solution for pile interaction by Randolph & Wroth (1979) is based on the solution for single pile (Randolph & Wroth, 1978) and extended for pile groups based on principle of superposition. A stiffness matrix relating load,  $P_t$  and settlement,  $w_t$  is then obtained with the pile length incorporated into the matrix as a constant. The method is based on the superposition of individual pile displacement fields, considering the average behaviour down the pile shafts separately from that beneath the level of the pile bases.



**Fig. 38** Schematic of piled raft system with varying pile lengths for medium-rise buildings.

It must be noted that the iterative analysis is proposed to enable pile-soil-structure interaction analysis be carried out using commonly available software within reasonable time and computer resources for practical design purposes. The analysis can also be carried out using Finite Element Method (FEM) software (e.g. PLAXIS 3-D Foundation) that can model 3-dimensional pile-soil-structure interaction. However, the FEM software will have great limitation on the numbers of piles that can be modelled practically.

Results of the analyses, such as pile reactions and settlements, are then checked against design criteria adopted to ensure the pile capacities are not exceeded and the settlements are within allowable limits.

In this paper, the interaction of piles is based on the solutions of Randolph & Wroth (1979). However, it should be highlighted that the original solution of Randolph & Wroth (1979) and subsequently adopted in the software

Therefore, for cases with different pile lengths, the interaction of the pile base at different levels is very complicated and its effect to shear stress along pile shaft unknown. However, for the current application in soft ground, the pile capacity is derived primarily from shaft/skin friction with very little end-bearing contribution. Therefore the original equation proposed by Randolph & Wroth (1979) can be rewritten with pile length as variable where every single pile in the group can be assigned different values of pile length. This has been incorporated in the Authors' firm internally developed software, Pile Group Analysis Using Elastic or Non-linear Soil Behaviour, PIGEON (Chow, C.M. & Cheah, S.W., 2003).

#### 4.3 Case Histories

##### 4.3.1 Mixed Development Overlying Highly Compressible Soft Clay

This development comprises of residential and commercial

units at a site of about 1200 acres at Bukit Tinggi, Klang, Malaysia, which is about 40km towards south west of Kuala Lumpur. This development was constructed over soft silty clay, termed as Klang Clay. The detailed descriptions of the Klang Clay were reported by Tan et al. (2004) and generally consist of alluvial deposits of very soft to firm silty clay up to a depth of 25m to 30m with presence of intermediate sand layers.

The foundation system adopted for the low-rise buildings generally consists of 150mm x 150mm x 9m length reinforced concrete (RC) square piles interconnected with 350mm x 600mm strips and 150mm thick raft. The view of recently completed houses are shown in Figures 39 and 40.



**Fig. 40** View of recently completed bungalow houses.

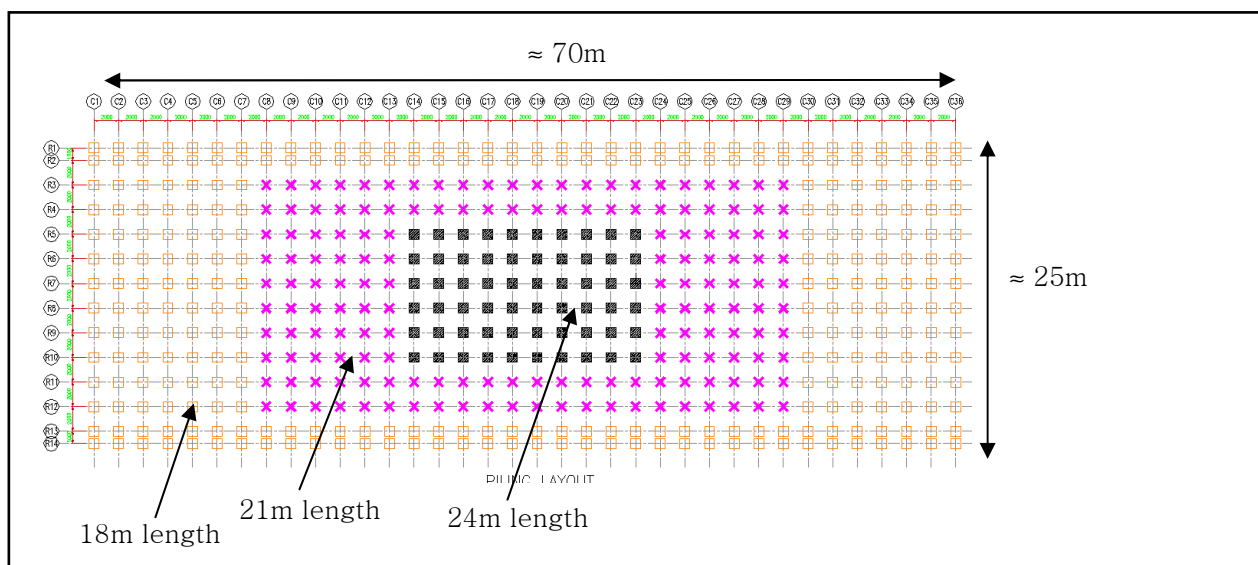
As presented earlier, the performance of the foundation system is proven adequate based on settlement monitoring results.

The foundation system adopted for the medium-rise buildings (5-storeys low cost apartment) generally consists of 200mm x 200mm (RC) square piles with pile length varying from 18m to 24m interconnected with 350mm x 700mm strips and 300mm thick raft. Figures 41 and 42 show typical piling layout for low cost apartment and view of the recently completed low cost apartment respectively.

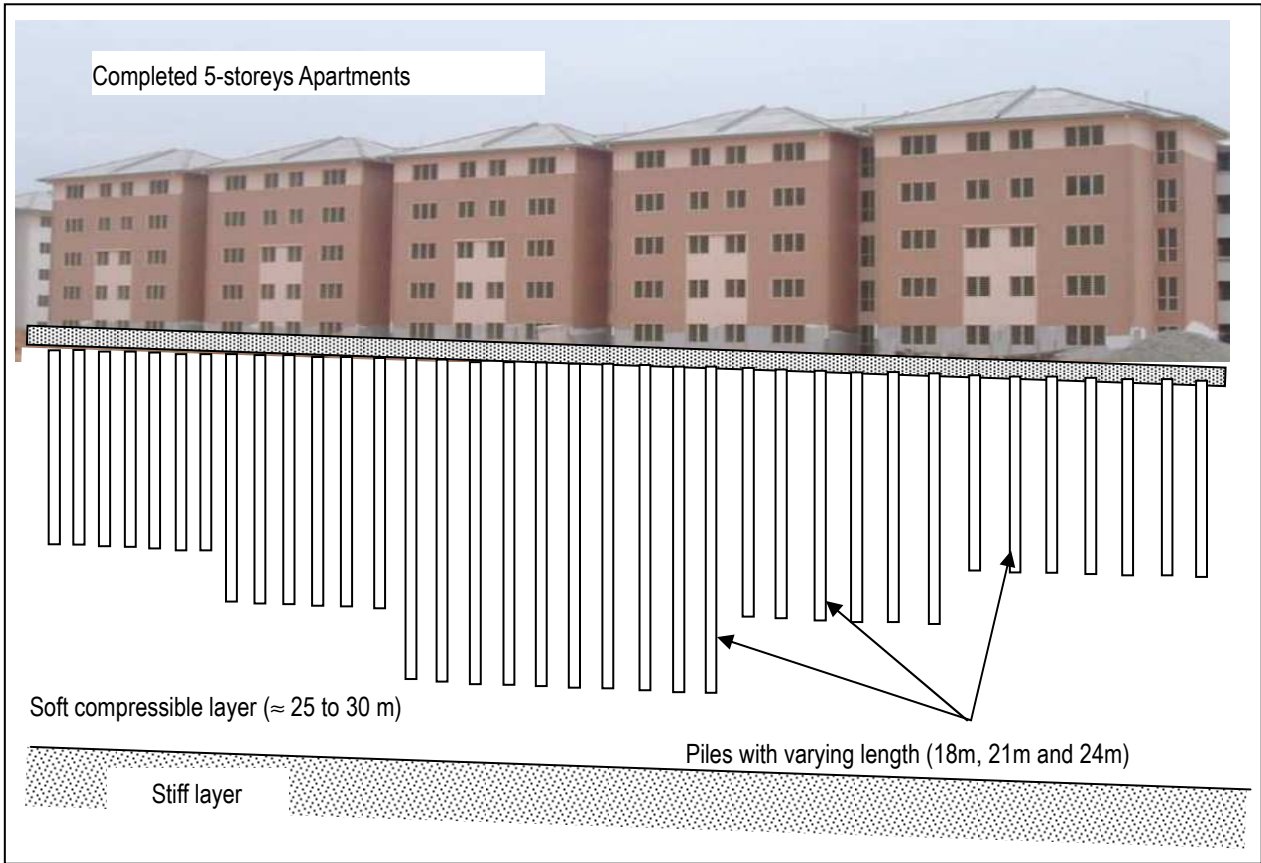
Settlement monitoring is also carried out for the low cost apartments and the results were reported by Tan et al., 2005 and Tan et al., 2006. Some of the monitoring results are presented in Figures 43 while Figure 44 shows the locations of the column settlement markers.



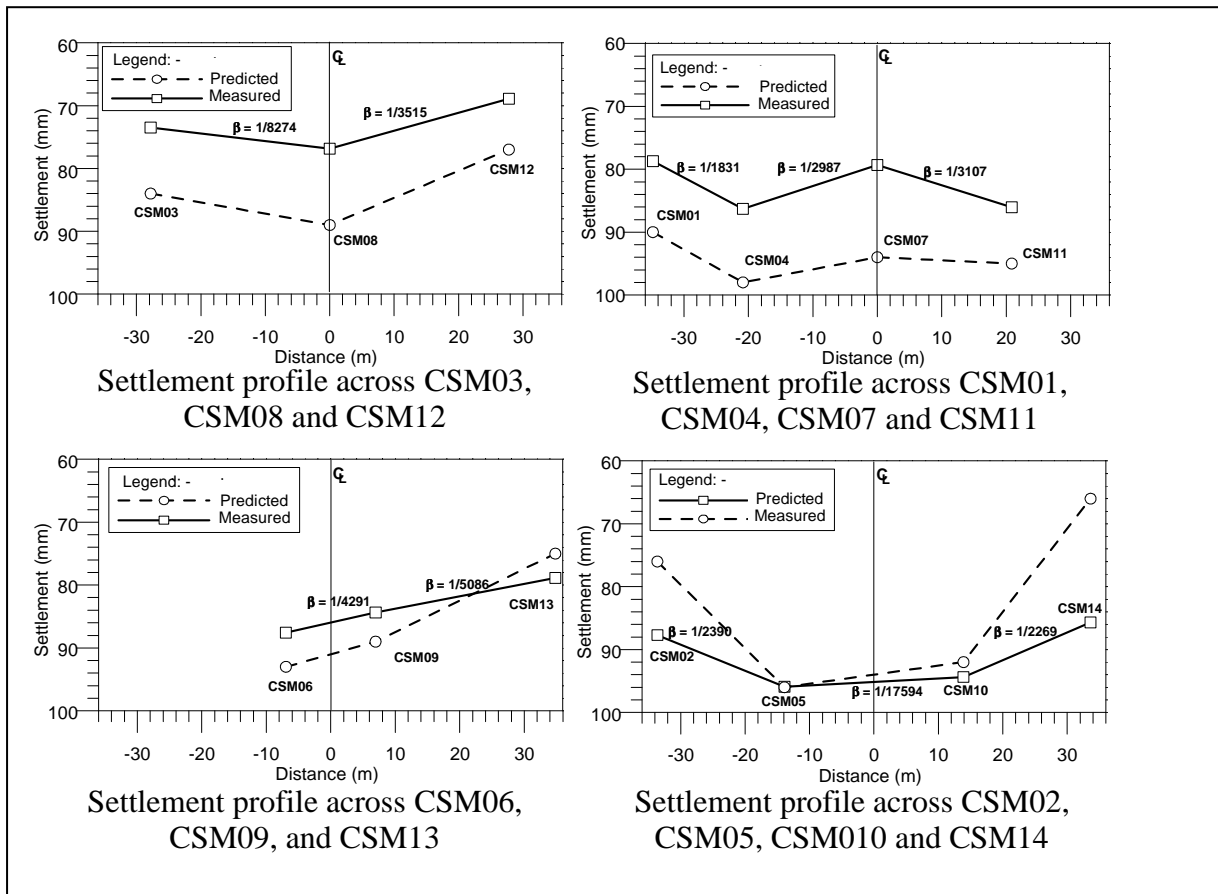
**Fig. 39** View of recently completed terrace houses.



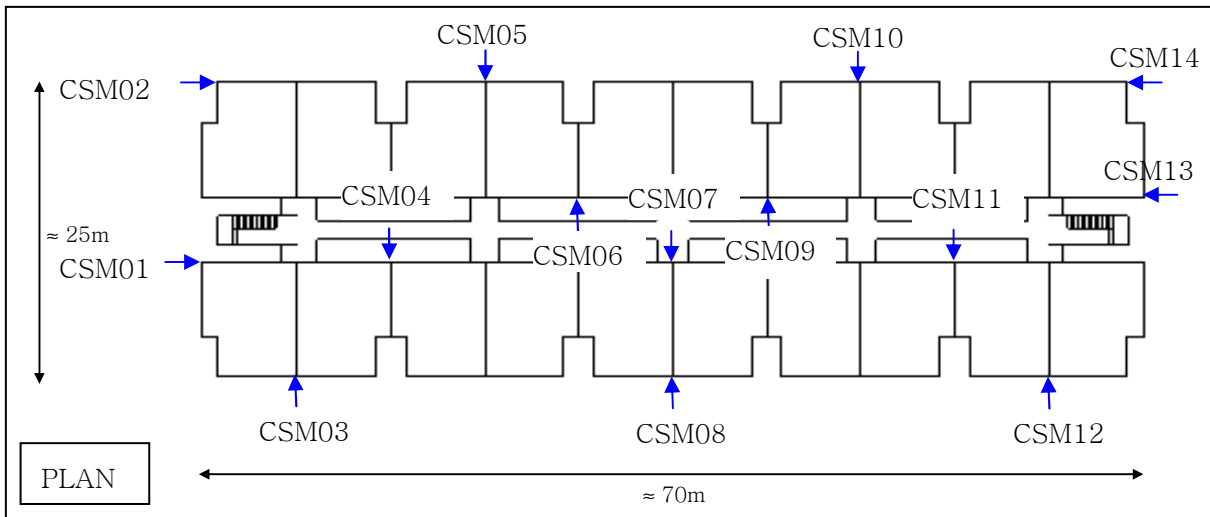
**Fig. 41** Typical piling layout for low cost apartments.



**Fig. 42** View of recently completed low cost apartments with superimposed schematic drawing of piled raft system.



**Fig. 43** Settlement profile across settlement markers.

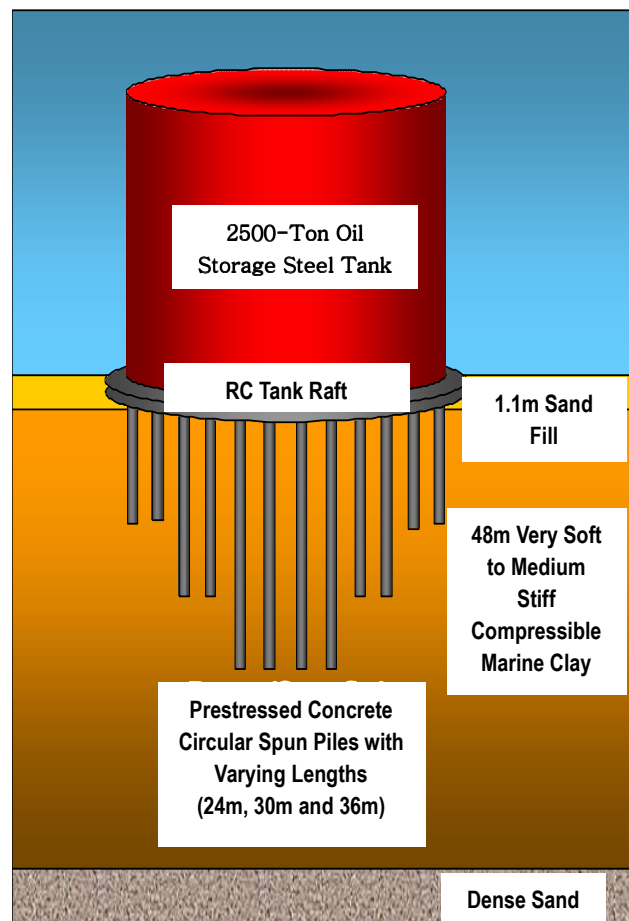


**Fig. 44** Locations of column settlement markers.

#### 4.3.2 2500-Ton Oil Storage Tank on Very Soft Alluvium Deposits

A palm oil mill has been constructed over sand filled platform with an area of about 83,000m<sup>2</sup> on soft swampy ground. The proposed site is located about 50km away from Sg. Guntung of Province of Riau, Sumatra, Indonesia. The subsoil conditions of the site generally consist of top one metre of organic materials of peat and decayed tree roots at the surface with no obvious desiccated weathered crust. The top 5m of the subsoil has over-consolidation ratio (OCR) of 1.6 at the top and gradually reduces to 1.0. Underneath the organic materials, the subsoil mainly consists of very soft normally consolidated clayey deposit of 34m thick followed by 12m thick medium stiff clay overlying the white medium dense fine sand and dense clayey sand.

The tank structure consists of a 12.2m high steel tank with external diameter of 17.5m and shell plate thickness of 8mm. All the tanks with coned-down base slope of 1/39 are seated on the 0.5m thick sand bed contained on the 0.5m thick reinforced concrete (RC) raft. There are a total of 137 numbers of 350mm diameter hollow circular prestressed concrete spun piles spaced at 1.5m square grids. Piles with lengths of 24m (68 piles), 30m (48 piles) and 36m (21 piles) respectively have been strategically located with the longer piles at the centre rim and shorter piles at the outer rim of the raft to control the raft distortion under the total imposed loading of about 3500 ton. Figures 45 and 46 show the schematic of the piled raft foundation system and view of the completed tank respectively. The design and instrumentation results of the tank foundation have been presented by Liew et al. (2002).



**Fig. 45** Schematic of piled raft foundation system.



**Fig. 46** View of completed tanks.

## 5 CONCLUSION

The practice of geotechnical engineering in Malaysia is basically self-regulated which encourages innovations in order to value add and be competitive. As such, various foundation systems have been adopted in Malaysia in order to meet market demand. Traditional pile foundations such as precast driven RC piles, bored piles and micropiles are currently being supplemented by relatively newer systems such as jack-in piles and ground improvement methods such as stone columns, cement mixing, etc. Due to increasingly scarce “good” soil conditions for developments, increasingly complex and innovative solutions are being adopted in Malaysia such as piled raft foundation and “floating” foundation system in soft ground conditions. Such competitive approach is encouraged as it will further advance the practice of geotechnical engineering in Malaysia. However, understanding of fundamental soil mechanics and geotechnical engineering is important to ensure safety and to uphold the integrity and professionalism of the industry. In this respect, university and learned societies such as the Institution of Engineers, Malaysia (IEM) and Chinese Institute of Engineers (CIE) have important roles to play. The exchange of experiences between countries and to learn from each other’s successes and failures is important in order to continuously improve and to prevent “re-inventing the wheel”.

## REFERENCES

- Azam, T., Hashim, H. & Ibrahim, R. (1996). Foundation design for Petronas Twin Towers at Kuala Lumpur City Centre. Proc. 12th SEAGC, Kuala Lumpur, 485-492.
- Bjerrum, L. (1957). Norwegian experiences with steel piles to rock. *Geotechnique*, Vol. 7, pp. 73-96.
- Bruce, D.A., DiMillio, A.F. & Juran, I. (1997). Micropiles: the state of practice. Part 1: Characteristics, definitions and classifications. *Ground Improvement*, 1, pp. 25-35.
- Burland, J.B. & Kalra, J.C. (1986). Queen Elizabeth II Conference Centre: geotechnical aspects. Proc. Instn Civ. Engrs, Part 1, No. 80, pp. 1479-1503.
- Chan, S.F. & Ting, W.H. (1996). Micropiles. Proc. 12th SEAGC, Kuala Lumpur, Malaysia, 93-99.
- Chow, C.M. & Cheah, S.W. (2003). PIGEON (Scientific Manual). Gue & Partners In-house Publication.
- Chow, C.M. & Tan, Y.C. (2009). Jack-in pile design – Malaysian experience and design approach to EC7. IEM Course on Eurocode 7 – Geotechnical Design, Petaling Jaya, Selangor, Malaysia.
- Chin, F.K. (1970). Estimation of the ultimate load of piles not carried to failure. Proc. 2nd SEA Conference on Soil Engineering, Singapore, 81-90.
- Chin, F.K. (1978). Diagnosis of pile condition (Guest Lecture). 5th SEA Conf. on Soil Engineering, Bangkok (also published in *Geotechnical Engineering*, Vol. 9, 1978)
- Chin, F.K. (1985). The design and construction of high embankments on soft clay. Proc. 8th SEAGC, Kuala Lumpur, Malaysia, 42-59.
- Chin, F.K. (1988). *The Penang Bridge: Planning, Design and Construction*. Malaysian Highway Authority, 1st Edition.
- Deeks, A.D., White, D.J. & Bolton, M.D. (2005). A comparison of jacked, driven and bored piles in sand. Proc. 16th ICSMGE, Osaka, Japan, 2103-2106.
- FHWA. (2000). *Micropile design and construction guidelines*. Federal Highway Administration, US Department of Transportation, USA.
- Gue, S.S. & Liew, S.S. (1998). Design, installation and performance of micropiles in Kuala Lumpur area, Malaysia. Proc. 13th SEAGC, Taipei, Taiwan, ROC, pp. 503-509.
- Gue, S.S. (1999). Foundations in limestone areas of peninsular Malaysia. Civil and Environmental Engineering Conference (C&EEC) New Frontiers & Challenges, Bangkok, Thailand.
- Gue, S.S., Chow, C.M., Cheah, S.W., Nik Airina & Mohd. Zulaistri (2007). Performance of reinforced concrete raft to remedy ‘mushroom’ problem of piled embankment with individual pilecaps on soft ground. Proc. 16th SEAGC, Kuala Lumpur, Malaysia.
- Horvath, R.G. (1978). Field load test data on concrete to rock bond strength. University of Toronto, Publication No. 78-07.
- Jakucs, L.D. (1977). *Morphogenetics of karst regions*. Translated by Balkay, Adam Hilger, Bristol, pp. 283.
- Jennings, J.N. (1982). Principles and problems in reconstructing karst history. *Helicite* 20(2), pp. 37-51.
- Juran, I., Bruce, D.A., DiMillio, A. & Benslimane, A. (1999). Micropiles: the state of practice. Part II: design of single micropiles and groups and networks of micropiles. *Ground Improvement*, 3, pp. 89-110.
- Liew, S. S., Gue, S.S. & Tan, Y.C. (2002). Design and instrumentation results of a reinforcement concrete piled raft supporting 2500 ton oil storage tank on very soft alluvium deposits. 9th International Conference on Piling and Deep Foundations, Nice, 3rd – 5th June, 2002, pp. 263-269.
- Love, J.P. (2003). Use of settlement reducing piles to

- support a raft structure. Proc. Instn Civ. Engrs, 156, No. 4, pp. 177-181.
- Mitchell, J.M. (1985). Foundations for the Pan Pacific Hotel on pinnacled and cavernous limestone. Proc. 8th SEAGC, Kuala Lumpur, Malaysia, Vol. 1, pp. 4/29-4/44.
- Neoh, C.A. (1998). Design & construction of pile foundations in limestone formation. Journal – Institution of Engineers, Malaysia, Vol. 59, No. 1, pp. 23 – 38.
- Poulos, H.G. (2000). Foundation settlement analysis – practice versus research. The Eight Spencer J. Buchanan Lecture, Texas, USA.
- Poulos, H.G. (2001). Piled raft foundations: design and applications. Geotechnique, Vol. 51, No. 2, pp. 95-113.
- Projek Lebuhraya Utara-Selatan Berhad, PLUS (1990), Seminar on Geotechnical Aspects of the North-South Expressway, Chin, C.H., M.J.D. Dobie & R.A. Nicholls (Eds), 5th and 6th November 1990, Kuala Lumpur, Malaysia.
- Randolph, M.F. & Wroth, C.P. (1978). Analysis of deformation of vertically loaded piles, Journal of the Geotechnical Engineering Division, Proc. of the ASCE, Vol. 104, No. GT12, pp. 1465-1488.
- Randolph, M.F. & Wroth, C.P. (1979). An analysis of the vertical deformation of pile groups, Geotechnique 29, No. 4, pp. 423-439.
- Randolph, M. F. (1994). Design methods for pile groups and piled rafts. Proc. 13th ICSMFE, New Delhi, Inde, pp. 61-82.
- Rosenberg, P. & Journeaux, N.L. (1976). Friction and end bearing tests on bedrock for high capacity socket design. Canadian Geotechnical Journal, 13, pp. 324-333.
- Tan, Y.C., Chen, C.S. & Liew, S.S. (1998). Load transfer behaviour of cast-in-place bored piles in tropical residual soils. Proc. 13th SEAGC, Taipei, Taiwan, ROC, pp. 563-571.
- Tan, Y.C., Chow, C.M. & Gue, S.S. (2004). Piled raft with short piles for low-rise buildings on very soft clay. 15th SEAGC, Bangkok, Thailand (also published in Geotechnical Engineering Journal, Volume 36, Issue 1, April 2005).
- Tan, Y.C., Chow, C.M. & Gue, S.S. (2005). Piled raft with different pile length for medium-rise buildings on very soft clay. 16th ICSMGE, Osaka, Japan.
- Tan, Y.C., Cheah, S.W. & Taha, M.R. (2006). Methodology for design of piled raft for 5-storey buildings on very soft clay. Shanghai Geotechnical Conference, Shanghai, China.
- Tan, Y.C. & Chow, C.M. (2006). Foundation design and construction practice in limestone area in Malaysia. HKIE-IEM Seminar on Geotechnical Works in Marble, Hong Kong.
- Terzaghi, K. (1955). Evaluation of coefficients of subgrade reaction. Geotechnique, Vol. 5, No. 4, pp. 297-326.
- Ting, W.H. (1985). Foundation in limestone areas of Malaysia. Proc. 8th SEAGC, Kuala Lumpur, Malaysia, 125-136.
- Ting, W.H., Chan, S.F. & Ooi, T.A. (2004). Achievements in geotechnical engineering practice in Malaysia (Keynote Lecture). Proc. Malaysian Geotechnical Conference, Selangor, Malaysia, 3-17.
- Toh, C.T., Ooi, T.A., Chiu, H.K., Chee, S.K. & Ting, W.H. (1989), Design Parameters for Bored Piles in a Weathered Sedimentary Formation, Proceedings of 12th International Conference on Soil Mechanics and Foundation Engineering, Rio de Janeiro, Vol.2, pp.1073-1078.
- Tomlinson, M.J. (1995). Foundation design and construction. 6th edn. Longman.
- Williams, A.F. & Pells, P.J.N. (1981), Side Resistance Rock Sockets in Sandstone, Mudstone, and Shale. Canadian Geotechnical Journal, 18, pp. 502-513.
- Yeap, E.B. (1985). Irregular topography of the subsurface carbonate bedrock in the Kuala Lumpur area. Proc. 8th SEAGC, Kuala Lumpur, Malaysia.
- Yamashita, K., Kakurai, M. & Yamada, T. (1994). Investigation of a piled raft foundation on stiff clay. Proc. 13th ICSMFE, New Delhi, Inde, pp. 543-546.