

# Soil Nailing for Slope Strengthening

Liew Shaw-Shong

*Gue & Partners Sdn Bhd, Kuala Lumpur, Malaysia*

**ABSTRACT:** Passive soil nailing technique has gained popularity for temporary and permanent slope strengthening works at both in-situ cut slopes of virtually any formations and also man-made filled slopes in Malaysia. However, there are still many misconception and myth in the design and construction of soil nails. Various design and construction practices have been adopted in the local industry of soil nailing works. This paper presents some of the common conventional design and construction practices in detail.

## 1.0 HISTORY OF SOIL NAILING

Soil nailing technique has been applied to civil engineering project at Mexico City back to 1960s and has gained popularity in Europe since 1970. During the development of soil nailing technique, cementitious grouted drilled nail, post-grouted driven nail, percussion-driven nail, jet nail, and etc have been devised and improved.

## 2.0 ADVANTAGES AND DISADVANTAGES OF SOIL NAILING

Hereafter, the advantages and disadvantages of soil nailing are briefly discussed.

### Advantages :

1. Allow in-situ strengthening on existing slope surface with minimum excavation and back-filling, particularly very suitable for uphill widening, thus environmental friendly,
2. Allow excellent working space in front of the excavation face,
3. Sub-vertical cut surface reducing loss of space,
4. Avoid unnecessary temporary works,
5. Only requires light machinery and equipment,
6. Flexible at constraint site and excavation shape,
7. Can be used for strengthening of either natural slope, natural or man-made cut slopes,
8. Robust and higher system redundancy,
9. Thinner facing requirement.

### Disadvantages :

1. Nail encroachment to retained ground rendering unusable underground space,
2. Generally larger lateral soil strain during removal of lateral support and ground surface cracking may appear,
3. Tendency of high ground loss due to drilling technique, particularly at coarse grained soil,
4. Less suitable for coarse grained soil and soft clayey soil, which have short self support time, and soils prone to creeping,
5. Lower mobilised nail strength at lower rows of nailing,
6. Suitable only for excavation above groundwater.

## 3.0 SUITABILITY OF SOIL NAILING WITH RESPECT TO SOIL TYPES

As soil nail construction requires temporary stability in both the staged excavation and also the drilled-hole stability, any soils with sufficient temporary self-support of about 2m sub-vertical height for minimum of 1 to 2 days and hole stability for minimum four hours are considered suitable ground for soil nailing.

With the above criteria, the following soil types would be suitable for soil nailing:

- i. Stiff fine/cohesive soils
- ii. Cemented granular soils
- iii. Well graded granular soils with sufficient apparent cohesion of minimum 5kPa as maintained by capillary suction with appropriate moisture content

- iv. Most residual soils and weathered rock mass without adverse geological settings (such as weak day-lighting discontinuities, highly fractured rock mass, etc) exposed during the staged excavation
  - v. Ground profile above groundwater level
- Soil nailing can still be considered suitable for certain soil types or ground conditions if proper drilling equipment and flushing agent are carefully selected.

The major impacts to soil nailing works in the unsuitable ground conditions are mostly :

- i. Loss of grout though the fractured rock mass, open joints and cavities
- ii. Collapse of drilled-hole
- iii. Poor nail-to-soil interface resistance due to disturbance of drilled-hole
- iv. Localized face stability

#### 4.0 DESIGN OF SOIL NAILING

The following documents have been widely referred by designers in designing the soil nailing strengthening works.

- a. BS8006:1995 Code of practice for Strengthened/reinforcement soils and other fills
- b. Federal Highway Administration (FHWA) : Manual for Design & Construction Monitoring of Soil Nail Walls
- c. BS8081:1989 Code of practice for Ground Anchorage

#### 4.1 REINFORCEMENT CONCEPT OF SOIL NAILING

Soil nail is basically a steel bar encapsulated in a cementitious grout to transfer tensile load from less stable active zone of retained soil mass to the more stable passive zone. Typically, soil nails are spaced at close spacing to achieve massive soil-nail interaction within the soil mass for its reinforcement effect. Typical soil nail spacing can be from 1m to 2.5m in either horizontal or vertical directions. Figure 1 shows the typical modes of reinforcing actions, namely tensile, flexural and shearing/dowelling effects. It has been well established that, for typical type II deformed bar soil nail, tensile stress in the nail has relatively more contribution to the reinforcing effect when comparing to the flexural and shearing/dowelling capacities of the nail. The efficiency of the reinforcing effect in terms of tensile, flexural and shearing/dowelling action is related to the inclination of the nail with respect to the ruptured surface, and the stiffness of the nail element in the aforementioned three actions. It was evident that the contribution in flexural and shearing/dowelling action of soil nail at best only improve

the nail resistance by few percents, therefore these effects are normally ignored in the design.

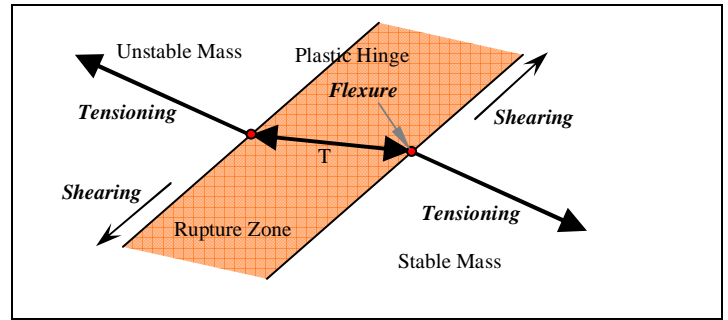

Figure 1 Effect of Soil Nail in Reinforcing the Soil Mass

The fundamental reinforcement of nail takes part in (a) partially increasing the normal stress on the sliding surface, hence improving the shear strength, (b) directly reducing the disturbing/destabilizing force of the reinforced soil mass, which is mostly due to the practically horizontal or sub-horizontal nail inclination. As a passive system, all above-mentioned actions will require deformation of the soil mass to mobilize the nail strength. There are two modes of soil nail mobilization in relation to the ground movements. Firstly, this can be achieved by the alternate top down sequence between excavation and nail installation. Stress relief, predominantly horizontally, will occur with excavation of soil mass. The earlier inclusion of nails will restraint the stress relief and partially maintains the internal stress. This mode of mobilization process is best illustrated by progressive nailing with the staged cutting of slope. Secondly, the on-going ground movements of a marginally stabilized ground can also mobilize soil nail without any stress relief from excavation. When comparing the two modes of ground movement, the earlier mode will have earlier mobilization at the upper nails and under-mobilized lower nails. Whereas the later mode have more uniform mobilization of the installed nails as the nails are most likely mobilized at the same time with the ground movement.

#### 4.2 COMPONENT DESIGN OF SOIL NAIL

In general, soil nail design usually requires to cover the following subjects.

##### 4.2.1 Nail Element

The soil nail element plays the major role in providing support to the slope mass. In this section, the design approach and considerations are elaborated in details.

Corrosion protection can be achieved by adequate grout cover, galvanization and encapsulation. However, fissured cracks within the grout body when nail is subject to tension usually prohibit permanent application of soil nailing design. For per-

manent application, galvanization and encapsulation shall be considered.

Centralisers are important elements to ensure achieving full nail capacity and adequate grout cover for durability. If the nail reinforcement is not centralised and when the nail reinforcement is stretched during mobilizing the nail force, flexural stresses will exist within the nail causing cracking and shattering of grout.

For nail element, there are three aspects controlling the nail resistance, namely grout-soil strength, nail head strength and structural strength of nail reinforcement. Figure 2 shows the typical nail resistance envelopes of the three controlling components. The minimum of the three envelopes would be the failure envelop indicating the available nail resistance where the slip surface intercepting the nails.

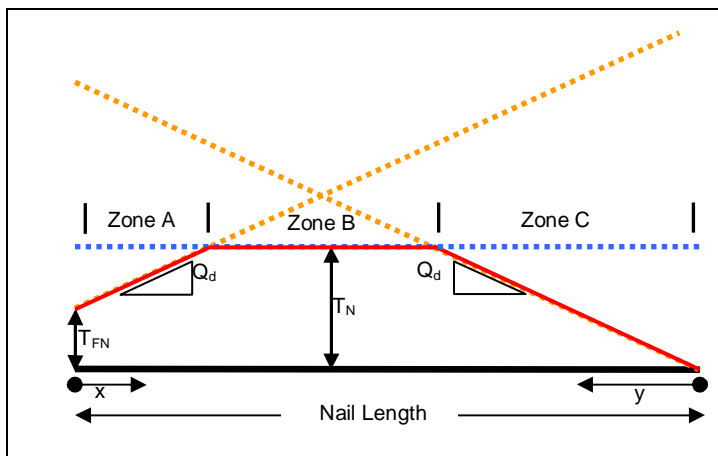

Figure 2 Nail Support Diagram

If the slip intercepts within Zone A, nail support force will be  $T_{FN} + Q_d \times x$ .

If the slip intercepts within Zone B, nail support force will be  $T_N$ .

If the slip intercepts within Zone C, nail support force will be  $Q_d \times y$ .

The nail support force can be used in the limit equilibrium stability assessment.

### Grout-Ground Strength

The grout-ground strength shall be assessed with considerations of material type, soil/rock strength, method of drilling (roughness of drilled hole), hole cleaning, open hole duration, hole diameter, grouting method and the groundwater condition. FHWA has tabulated some recommended ultimate grout-ground resistance as in Table 1. For larger hole size, the ultimate grout-ground resistance would be less than the one with smaller hole size. This is primary due to relatively poor confinement and higher stress relief for larger drilled hole. For fine cohesive soils, the ultimate grout-ground resistance

can be 0.25 to 0.75 times of the undrained shear strength.

In BS8081, four types of grouting methods (Types A, B, B and D) are allowed. These grouting methods have different impact on the nail bond strength. The pull out test results summarised in BS8110 seem to suggest reducing ultimate grout-ground strength with increasing fixed length. This is no surprise as the nail is still a elastic medium, which will elongate and mobilize different level of grout-ground interface strength when subject to tensioning.

Table 1 Recommended Ultimate Grout-Ground Resistance (FHWA)

Construction Method	Material Type	Ultimate Grout-Soil Resistance (kPa)
Open Hole	Non plastic silt	20 ~ 30
Open Hole	Medium dense sand & silty sand/sandy silt	50 ~ 70
Open Hole	Dense silty sand & gravel	80 ~ 100
Open Hole	Very dense silty sand & gravel	120 ~ 240
Open Hole	Loess	25 ~ 75
Open Hole	Stiff clay	40 ~ 60
Open Hole	Stiff clayey silt	40 ~ 100
Open Hole	Stiff sandy clay	100 ~ 200
Rotary Drilled	Marl/Limestone	300 ~ 400
Rotary Drilled	Phyllite	100 ~ 300
Rotary Drilled	Chalk	500 ~ 600
Rotary Drilled	Soft dolomite	400 ~ 600
Rotary Drilled	Fissured dolomite	600 ~ 1000
Rotary Drilled	Weathered sanstone	200 ~ 300
Rotary Drilled	Weathered shale	100 ~ 150
Rotary Drilled	Weathered schist	100 ~ 175
Rotary Drilled	Basalt	500 ~ 600

In Malaysia, the grout-ground interface resistance for residual soils can be assessed based on empirical expression using SPT-N values.

$$f_s = 5 \sim 6 \times \text{SPT-N (kPa)}$$

If the drilled hole is wet or saturated, caution shall be taken to downgrade the grout-ground interface resistance with verification of pull-out test.

If unrealistically high grout-ground interface resistance is used in the design, the installed nail will either faces the pull-out failure or experience excessive creep. It is not acceptable for soil nail having

creeping movement of more than 2mm in one log-cycle of holding time (says from 6 minutes to 60 minutes).

### Nail Head Strength

Nail head strength is primarily governed by the flexure and/or punching shear of the facings, and nail head connection.

### Flexural Strength

The flexural strength of the facing can be determined by the critical yield line theory for all types of nail arrangement. The recommended method by FHWA can be assessed by the following expression for ultimate flexural strength in which  $S_v$  is larger than  $S_h$  and vertical moment resistance is more critical. The expression is suitable for the steel reinforcement ratio in the facings less than 0.35%.

$$T_{FN} = C_F (m_{V,NEG} + m_{V,POS})(8S_h/S_v)$$

where

$T_{FN}$  : Critical nail head strength

$C_F$  : Flexure pressure factor (Table 2)

$m_{V,NEG}$  &  $m_{V,POS}$  : Vertical nominal unit moment resistance at the nail head and mid-span

$S_h$  &  $S_v$  : Horizontal/vertical nail spacings

For individual reinforced concrete pad facing and grid beam, the same approach by considering development of full development of positive and negative plastic moments can be used to the nail head strength. Figure 3 shows the typical pressure behind the facing.

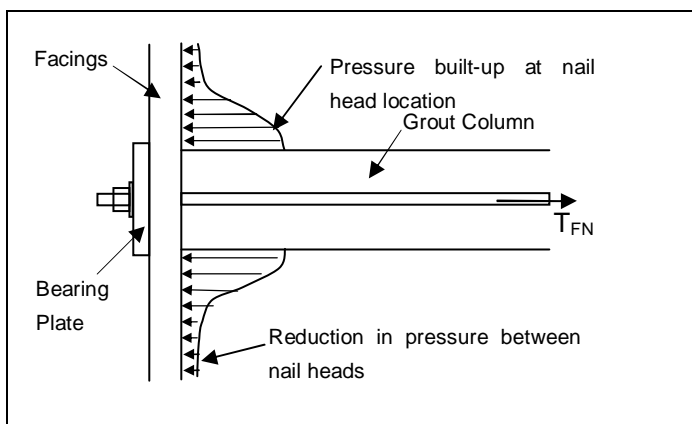

Figure 3 Typical Facing Pressure Distribution

### Punching Shear Strength

This failure mechanism consists of punching of a cone-shaped block of concrete facing centered about the nail head as shown in Figure 4. Bearing plate connection is popular type of nail head connection in Malaysia soil nailing industry. The design of punching shear for flat slab design can be referred to

BS8110. FHWA has also given similar ultimate punching assessment with the following expression.

$$T_{FN} = V_N \left[ \frac{1}{1 - C_s (A_c - A_{GC}) / (S_v S_h - A_{GC})} \right]$$

where

$C_s$  : Punching shear pressure factor (Table 2)

$A_c$  : Soil contact area of cone-shaped block

$A_{GC}$  : Cross sectional area of grout column

$V_N$  : Nominal internal punching shear strength

Table 2 Recommended Pressure Factors for Facing Design

Facings Thickness (mm)	Temporary Facings		Permanent Facings	
	$C_F$	$C_s$	$C_F$	$C_s$
100	2.0	2.5	1.0	1.0
150	1.5	2.0	1.0	1.0
200	1.0	1.0	1.0	1.0

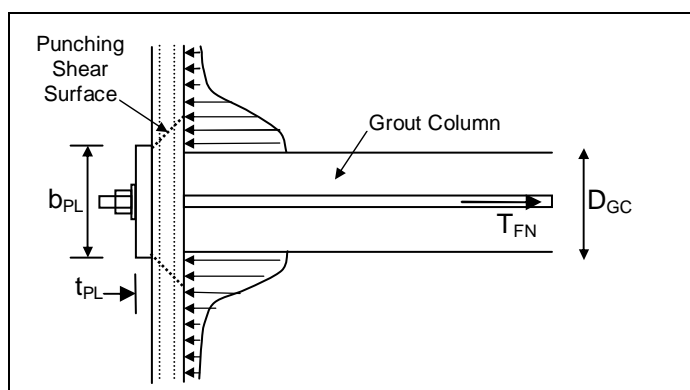

Figure 4 Typical Punching Shear of Bearing Plate Connection

The flexural stiffness of the facing increases with thickness and steel reinforcement ratio, and decreases with increasing nail spacing. The relatively low flexural facing stiffness and comparative high nail head support stiffness will encourage effective arching effect resulting in highly non-uniform pressure distribution between the mid-span of facing and nail head as shown in Figures 3 and 4. Therefore, the nail head strength may possibly be higher than the abovementioned assessment. Nevertheless, it would be conservative to ignore such arching phenomenon.

In addition to the above, it is also important that the geotechnical capacity of the nail head in terms of bearing capacity and passive failure of the arched soil formed between the nail heads. Shiu & Chang (2004) have reviewed the nail head design on the aspect of bearing capacity. Figure 5 shows the expression for lower bound nail head force of individual pad facing proposed by Department of Transport, UK. There is no simple assessment on the same for grid beam and shotcrete facing. It is believed that shotcrete facing would have sufficient bearing capacity if the facing stiffness is adequately large. In addition to the above, the passive failure of the soil arch would need more research and development. Three-dimensional finite element pro-

gram can be considered for such assessment despite it would be time consuming and need more computing power resource.

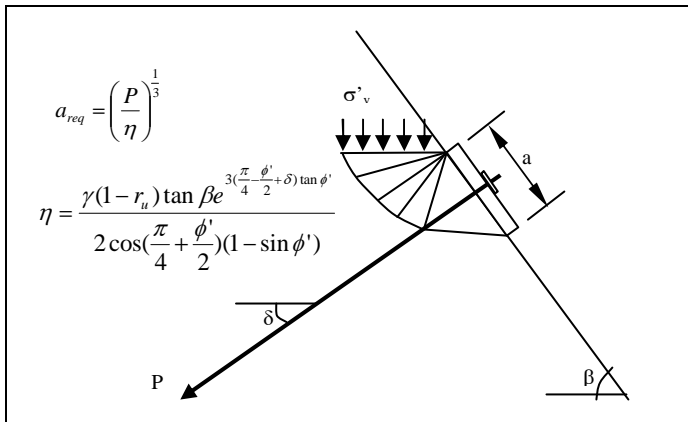

Figure 5 Lower Bound Nail Head Force for Individual Pad Facing

### Structural Tensile Strength of Nail Reinforcement

Based on BS8110, the ultimate tensile strength of the nail reinforcement,  $T_N = 0.87 \times f_y \times A_s$ .

### 4.2.2 Facing Element and Connection

There are three primary types of facing design for soil nail, namely, individual pad, grid beam/grillage beam, shotcrete/gunite. Figures 6 and 7 show the typical details of these facing elements. The structural design of the reinforced concrete elements can refer to BS8110 whereas the steel connection design shall refer to BS5950. It is also important to check the cantilever portion above the first row and beneath the lowest row of soil nails.

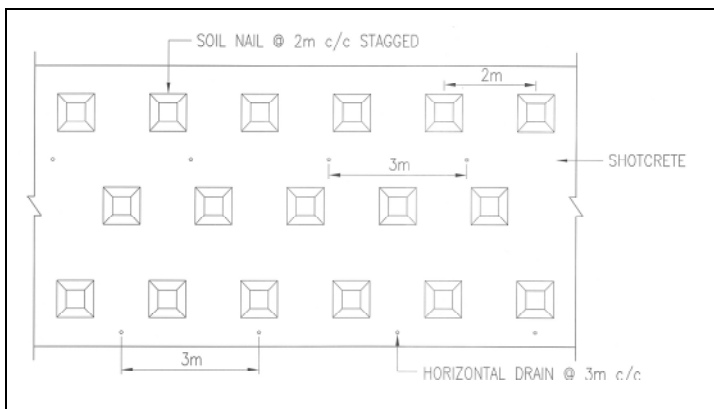

Figure 6 Shotcrete/Gunite Facings

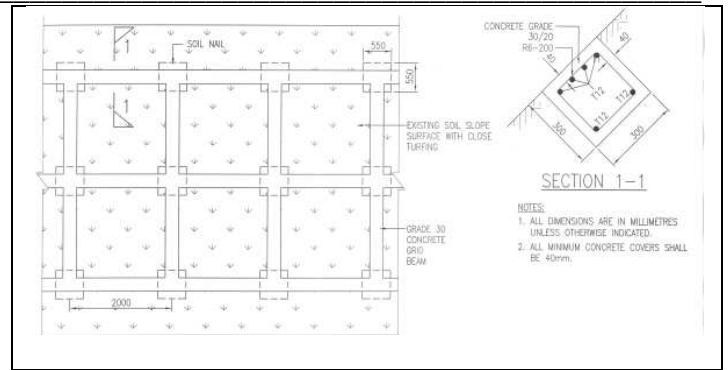

Figure 7 Grid Beam System

### 4.2.3 Surface and Subsurface Drainages

For most slope strengthening works, it is vitally critical to control the groundwater as it has significant impact on the safety factor. For efficient control of groundwater, horizontal subsoil drains are usually proposed at certain horizontal and vertical spacing to proactively lower the groundwater profile and depressurize excess pore pressure within the slope mass. If bedrock surface is encountered within the practical length (maximum 24m) of subsoil drain, it is always advisable to have the subsoil drain socket 0.5m into the bedrock to intercept perched water table over the bedrock. For rock mass where fractures and water seepage are observed, subsoil drains shall be installed at these locations.

If shotcrete/gunite is used as slope facing, it is vitally important to have sufficient weephole drains to prevent buildup of water pressure immediately behind the shotcrete/gunite facing. When clean interface at the weathered residual soil and bedrock can be identified, additional weephole drains shall be located immediately above the bedrock surface as perched water above the bedrock can rapidly build up water pressure behind the shotcrete/gunite surface. The same principle shall be applicable to the observable seepage spots on the exposed excavation surface.

Figures 8 and 9 show the typical details of horizontal subsoil drain and the weephole drains. For the subsoil drains, there are swellable water-stops at certain intervals to segmentise the annulus between the drain PVC pipe and the drilled-hole. This is to prevent excessive accumulation of water at the lower part of the drain before flowing into the drain pipe through the perforated holes or slots, and also internal erosion along the drilled-hole.



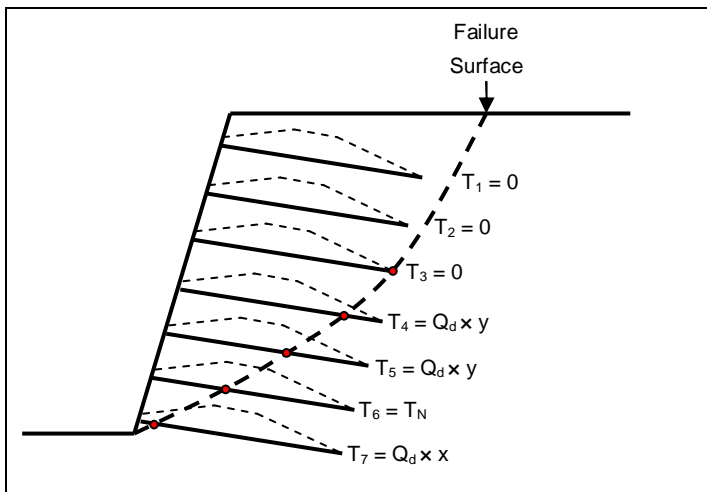

Figure 11 Adjustment of Soil Nail Load with respect to a specific Slip Surface

The safety factor of the soil nail slope assessment can refer to the recommendation by Geotechnical Engineering Office. Table 3 tabulates the safety factor requirements for consideration of loss of life and potential economic loss. Table 4 summarises the design safety factors for various modes of failure.

Table 3 Recommended Factors of Safety for New Slopes for a Ten-Year Return Period Rainfall

Economic Risk \ Risk to Life		Loss of Life		
		Negligible	Low	High
Economic Loss	Negligible	>1.0	1.2	1.4
	Low	1.2	1.2	1.4
	High	1.4	1.4	1.4

Note : In addition to FOS of 1.4 for a ten-year return period rainfall, a slope in the high risk-to-life category should have a FOS of 1.1 for the predicted worst groundwater conditions.

Table 4 Recommended Factors of Safety for various Failure Modes (Watkins & Powell, 1992)

Type	Failure Mode	FOS
External	Overturning	2.0
	Sliding	1.5
	Bearing Capacity	3.0
	Overall Stability	See Table 3
Internal	Pull-Out	2.0 (Grout-Ground) 2.0 (Grout-Steel)
	Tensile	$f_{max} < 0.55 f_y$
	Nail Head & Facing	3.0

#### 4.4 SERVICEABILITY ASSESSMENT

Generally, the lateral ground deformation for an adequately reinforced soil nailed slope or excavation typically ranges from 0.2% to 0.5% of the slope height or retained height. Finite element analysis can provide useful predictive magnitude and trend of the deformation profile. If any measured deformation exceeds the aforementioned range, caution should be taken to timely implement the contingency plan to prevent disastrous failure.

#### 5.0 CONSTRUCTION ASPECTS OF SOIL NAIL

##### 5.1 METHOD STATEMENT

For proper review and supervision by the design consultant, it is very important that method statement dictating how the works to be done in compliance to specification requirements and contractual obligation by the contractors and the equipment or resources available to him/her to be officially submitted. The sample specification of soil nailing work is enclosed in Appendix A of this paper. To assist and ease the supervision of soil nailing work, a supervision checklist is also enclosed in Appendix B. The typical method statement for soil nailing works shall consist of the following items:

##### 5.1.1 MACHINERY

The following equipment is necessary for soil nailing work.

##### Drilling Equipment

In Malaysia soil nailing industry, there are few common types of drilling equipment, namely rotary air-flushed and water-flushed, down-the-hole hammer, tri-cone bit. It is important to procure drilling equipment with sufficient power and rigid drill rods.

##### Grout Mixing Equipment

In order to produce uniform grout mix, high speed shear colloidal mixer should be considered. Powerful grout pump is essential for uninterrupted delivery of grout mix. If fine aggregate is used as filler for economy, special grout pump shall be used.

##### Shotcreting/Guniting Equipment

Dry mix method will require a valve at the nozzle outlet to control the amount of water injecting into the high pressurised flow of sand/cement mix. For controlling the thickness of the shotcrete, measuring pin shall be installed at fixed vertical and horizontal intervals to guide the nozzle man.

### **Compressor**

The compressor shall have minimum capacity to delivered shotcrete at the minimum rate of 9m<sup>3</sup>/min. Sometimes, the noise of compressor can be an issue if the work is at close proximity to residential area, hospital and school.

## 5.1.2 MATERIAL

### **Steel Reinforcements**

For corrosion protection, all steel components shall be galvanised. If machine threading after galvanisation is unavoidable, then proper zinc based coating shall be applied onto the thread. For double corrosion protection, the PVC corrugated pipe used shall be of good quality and adequate thickness. Preferably, galvanized corrugated steel pipe shall be used.

### **Grout Mix**

For conventional soil nail, the water cement ratio of the grout mix ranges from 0.4 to 0.5. As most cementitious grout will experience some grout shrinkage, non-shrink additive can be used to reduce breeding and grout shrinkage. The resistance at grout-soil interface of nail will significantly reduced when the grout shrink.

### **Shotcrete/Gunite**

Shotcrete or gunite can be continuous flow of mortal or concrete mixes projected at high speed perpendicularly onto the exposed ground surface by means of pneumatic air blowing for dry mix or spraying for wet mix. The high speed shooting mortal or concrete can produce self compacted cementitious mortal as the facing. In Malaysia, the dry mix method is more common as the equipment is relatively simple and requires less powerful delivery system. The only drawback of this method is the inconsistency of water-cement ratio as water is subjectively added to the nozzle by the operator. The water cement ratio of shotcrete mix is normally ranging from 0.35 to 0.5. Chemical curing compound or wet gunny sack can be normally used for curing of shotcrete. Sometimes, admixture can be used to speed up the setting time of the shotcrete.

The ground surface shall be conditioned before receiving the shotcrete. In general, the surface shall be trimmed to reasonably smooth surface without loose materials and seepage. The ground surface shall be maintained at moisture equilibrium between the soil and the shotcrete.

## 5.1.3 MAN-POWER

In the entire soil nailing work, the working team shall consist of drilling team of about four workers (1 rig operator, 2 helpers to joint/dismantle drill rods and change bits and one to control the compressor),

grouting team of three workers (2 for batching and mixing cementitious grout and 1 for controlling the grout pump), shotcrete team of four workers (1 nozzle man, 2 for batching cement, and 1 for controlling delivery system). Therefore, it is evident that soil nailing work requires high level of coordination and skill. Nozzle man is the one controlling the quality of the shotcrete both in terms of structural requirements and aesthetic. Without skillful and qualified workers, it is fairly difficult to assure quality product.

## 5.1.4 CONSTRUCTION SEQUENCE

Typical construction sequence of soil nails can be divided in the following stages :

### a. Initial excavation

This initial excavation will be carried out by trimming the original ground profile to the working platform level where the first row of soil nails can be practically installed. The pre-requisite of this temporary excavation shall be in such a way that the trimmed surface must be able to self support till completion of nail installation. Sometimes, sectional excavation can be carried out for soil with short self support time. If shotcrete/gunite is designed as facing element, the condition of the trimmed surface shall be of the satisfactory quality to receive the shotcrete.

### b. Drilling of holes

Drilling can be done by either air-flushed percussion drilling, augering or rotary wash boring drilling depending on ground condition. The size of drilled hole shall be as per the designed dimension. Typically, the hole size can range from 100mm to 150mm. In order to contain the grout, the typical inclination of the drill hole is normally tilted at 15° downward from horizontal. Flushing with air or water before nail insertion is necessary in order to remove any possible collapsed materials, which can potentially reduce the grout-ground interface resistance.

### c. Insertion of nail reinforcement and grouting

The nail shall be prepared with adequate centralisers at appropriate spacing and for proper grout cover for first defense of corrosion protection. In addition to this, galvanization and pre-grouted nail encapsulated with corrugated pipe can be considered for durability. A grouting pipe is normally attached with the nail reinforcement during inserting the nail into the drilled hole. The grouting is from bottom up until fresh grout return is observed from the hole. The normal range of water/cement ratio of the typical grout mix is from 0.45 to 0.5.

---

### 5.1.5 WORK PROGRAMME

Work programme shall be prepared by the work contractor based on the actual production rate of the equipment. Reasonable provision shall be allowed for provision of slow production in drilling through boulders or bedrock.

### 5.1.6 QA/QC TESTING

The following QA/QC tests shall be allocated in the tender, but not limited to:

- a. Preliminary and working pull out tests
- b. Cube specimens for grout mix
- c. Test panel of the shotcrete and cube strength test
- d. Tensile strength test for reinforcements and couplers.
- e. Checking on the galvanizing thickness of the steel reinforcement

## 6.0 CONCLUSIONS

This paper presents a brief overview of the soil nail design philosophy and methodology.

## REFERENCES

- BS5959. 2000, *Structural Use of Steelwork in Buildings*. British Standards Institute
- BS8006. 1995, *Code of Practice for Strengthened/Reinforced Soils and Other Fills*. British Standards Institute
- BS8081. 1989, *Code of Practice for Ground Anchorages*. British Standards Institute
- BS8110. 1997, *The Structural Use of Concrete*. British Standards Institute
- Federal Highway Administration, 1998. Manual for Design & Monitoring Construction of Soil Nail Walls.
- Shiu, Y. K. & Chang, G. W. K. 2004. *Soil Nail Head Review*. Special Project Report No. SPR 8/2004, Geotechnical Engineering Office, Hong Kong.
- Watkins, A. T. & Powell, G. E. 1992. *Soil Nailing to Existing Slope as Landslip Preventive Works*. Hong Kong Engineer, March issue, 1992, pp. 20-27