

DESIGN OF DISCONNECTED PILED FOUNDATION FOR 6.0m HIGH INLET STRUCTURE

Chee-Meng CHOW¹, Fei-Seong FONG² and Yean-Chin TAN³

¹Associate Director, G&P Geotechnics Sdn Bhd, Kuala Lumpur, Malaysia

²Senior Geotechnical Engineer, G&P Geotechnics Sdn Bhd, Kuala Lumpur, Malaysia

³Director, G&P Geotechnics Sdn Bhd, Kuala Lumpur, Malaysia

Email: ¹cmchow@gnpgeo.com.my, ²fsfong@gnpgeo.com.my, ³yctan@gnpgroup.com.my

ABSTRACT: Pile foundation is traditionally adopted when bearing capacity of the soil is inadequate and the use of pile foundation is efficient for the support of axial load of structures. The use of piles to support lateral load is less efficient especially for slender precast reinforced concrete piles in soft ground. In this paper, a design approach for a 6.0m high inlet structure for a flood mitigation project which is designed to support difference in water level up to 6.1m is described. Disconnected pile foundation is adopted where the pile is provided to support the axial loadings from the inlet structure while the lateral resistance is mainly provided by the friction between the interfaces of the structure with the soil. Other possibly more effective ground treatments such as stone columns are not used due to contractual restraint of the project. The use of disconnected pile foundation has resulted in significant reduction in overall pile quantities as large numbers of piles will be required to resist the lateral loading due to the low lateral capacity of the precast reinforced concrete piles.

1. INTRODUCTION

Damansara River located in the western part of the Klang River Basin of Selangor, Malaysia (Figure 1) has a total reach length of 24.7 km with catchment area of approximately 152 km². Over the past two decades, Damansara River catchments have undergone massive development due to economic and social demands. Such rapid development has led to huge amounts of sediment being transported downstream and deposited along Damansara River.

Damansara River now is the most critical catchment in the Lower Klang River Basin that requires utmost attention considering the frequent occurrence of severe floods in the last few years. The Subang Airport South (SAS) detention pond located on the right bank of Damansara River catchment is one of the flood mitigation components to mitigate river flooding problem along Damansara River catchment.

The SAS detention pond is designed to reduce the flood profile of Damansara River during the 5-year and 100-year ARI event. A side spill weir, i.e. "Inlet" is proposed to divert flood from the main river channel to the detention pond. Figure 1 shows the aerial photograph view together with the inlet structure location and layout plan of the proposed SAS pond.

1.1 Inlet Structure

The SAS inlet structure is a straight drop vertical weir with a height of 6.0m. With the inlet, the SAS detention pond system will not require any manual or mechanical operational works. The flood water will begin to flow into the detention pond through the inlet structure once the water level in Damansara River rises above the design weir crest level. It is designed in accordance with USBR Design of Small Dam guideline to support difference in water level up to 6.1m.

Several combinations of the pond inlet configurations have been numerically simulated to study the combined optimum effectiveness of the pond with the inlet in reducing the design flood profile of Damansara River. From the study, the optimum length and crest level of the SAS inlet into the pond is 80m and 8.0mRL respectively. Figure 2 shows view of the completed SAS inlet structure and the salient features of the inlet structure are tabulated in Table 1.

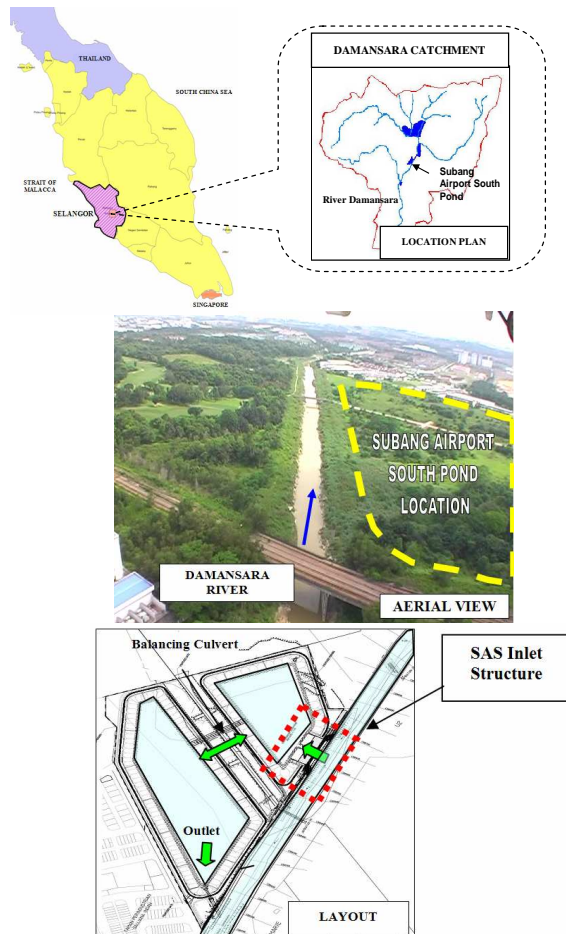

Figure 1 Location, Layout Plan and Aerial View of Proposed Subang Airport South Pond



Figure 2 View of the SAS Inlet Structure

Table 1 Salient Features of SAS Inlet Structure

SAS Inlet Structure	
Crest Level, (m)	8.00mRL
Stilling Basin Level, (m)	2.00mRL
Stilling Basin Length, (m)	19.90m
Wall Height, (m)	6.00m
Dead Storage Level, (m)	3.50mRL
Maximum Flood Level, (m)	9.60mRL

The merit of the adopted straight drop vertical weir inlet instead of ogee shaped weir is the profile of the vertical weir will not depend on the flow conditions and the weir crest level can be easily modified in the future, if the need arises. Figure 3 shows the layout, section and details of the inlet structure.

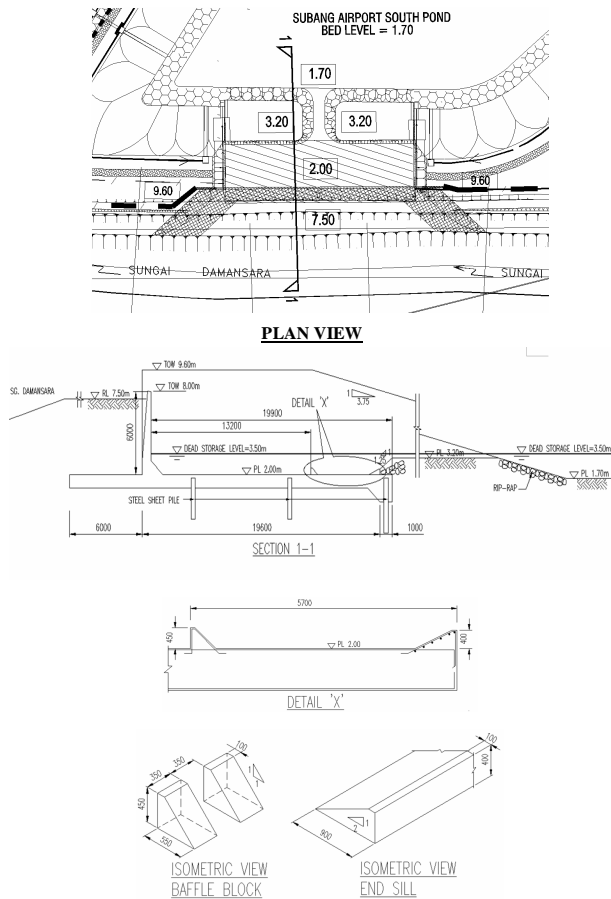

Figure 3 Layout, Section and Details of SAS Detention Pond Inlet Structure

The stilling basin is designed in accordance with USBR Design of Small Dam guideline with a row of impact or baffles blocks placed downstream of the stilling basin followed by an end sill. The basin relies on the turbulence of the jump phenomena and the dissipation of energy by the baffles blocks. The provision of the baffle blocks and end sill on the stilling basins floor shortens the hydraulic jump length and dissipates the high velocity flow within the shortened stilling basin length. The block will assist in energy dissipation even under a drowned jump condition.

2. SUBSURFACE INFORMATION

2.1 Site Geology and Subsoil Condition

The geological map of Selangor Darul Ehsan indicates that the inlet structure is predominantly underlain by Granite formation. The

overburden material generally consists of Sandy SILT and Clayey SILT. Soft deposits are expected at the inlet location due to deposition along the river.

Subsurface investigation (SI) works which consist of Boreholes (BH), Vane Shear (VS) tests and Mackintosh Probe (MP) tests have been carried out to establish subsurface conditions with necessary engineering parameters for the geotechnical and stability assessment of the inlet. The interpreted subsoil profiles from the boreholes and Mackintosh Probes are presented in Figure 4 and Figure 5 respectively.

The borelog profiles show that the subsoil stratum generally consists of alluvial deposits overlying the sandy layer. The thickness of the soft alluvial deposits (SPT-N <10) which generally consist of sandy SILT or silty SAND ranges from 3-9m. As the borelog profiles shown in Figure 4 is not at the exact inlet structure location but is from nearby boreholes along Damansara River, Mackintosh Probes were specified at the exact location of the SAS Pond inlet structure in order to ascertain the soil condition.

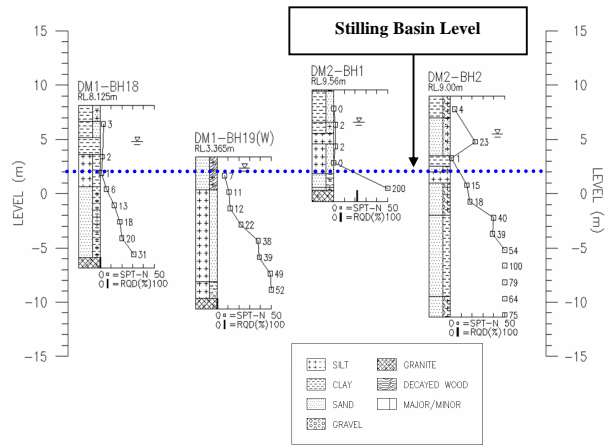

Figure 4 Subsoil Profile from Boreholes

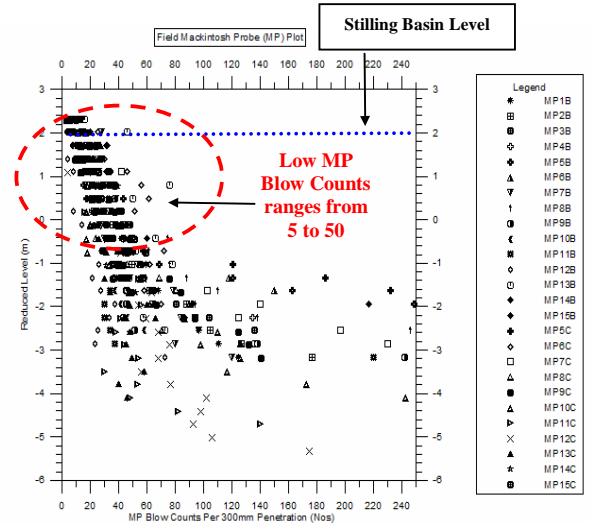

Figure 5 Mackintosh Probe Plot

From the field MP results, low MP blow counts ranging from 5 to 50 is obtained and as such, either some form of ground treatment or pile foundation is required in order to support the inlet structure with maximum induced bearing pressure of approximately 100kN/m².

2.2 Shear Strength Parameter

Penetrating vane shear tests were carried out to establish undrained shear strength profile of the subsoil in view of the low bearing

capacity implied in the MP results. The interpreted undrained shear strength profile is presented in Figure 5.

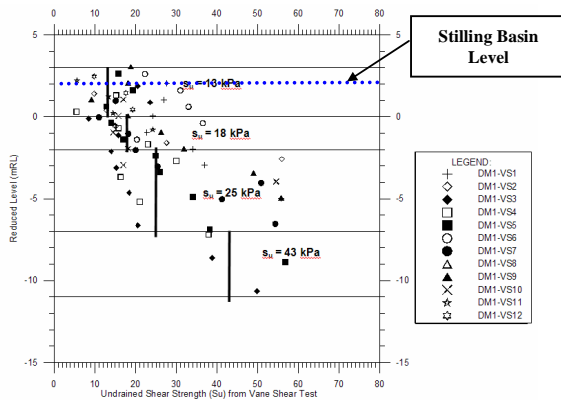

Figure 5 Undrained Shear Strength Plot from Vane Shear Test

Due to the soft ground condition with the interpreted undrained shear strength in the region of 13kPa to 18kPa, piles are required to provide sufficient bearing capacity in supporting the inlet wall. Other possibly more cost effective ground treatments such as stone columns are not used due to contractual restraint of the project.

3. DESIGN APPROACH OF INLET STRUCTURE

The inlet structure is designed following the stability criteria in accordance with EM1110-2-2100: Stability Analysis of Concrete Structure (USACE, 2005). The objective of a stability analysis is to maintain horizontal, vertical and rotational equilibrium of the structure. Stability of the structure is ensured by:

- Providing an adequate factor of safety against sliding at all possible failure plane.
- Providing specific limitations on the magnitude of the foundation bearing pressure.
- Providing an adequate factor of safety against floatation of the structure.

3.1 Sliding Stability

EM 1110-2-2100 has specifically stated the factor of safety required for sliding stability of the structure based on the load conditions as follows:-

Table 2 Factor of Safety Required for Sliding

Site Information Category	Loading Condition Categories		
	Usual	Unusual	Extreme
Well Defined	1.4	1.2	1.1
Ordinary	1.5	1.3	1.1
Limited	3.0	2.6	2.2

Table 3 Load Condition Probabilities Defined by EM1110-2-2100

Load Condition Categories	Annual Probabilities (p)	Return Period (tr)
Usual	Greater than or equal to 0.10	Less than or equal to 10 years
Unusual	Less than 0.10 but greater or equal to 0.0033	Greater than 10 years but less than or equal to 300 years
Extreme	Less than 0.0033	Greater than 300 years

As the design flood level of the inlet corresponds to 100-year ARI, the load condition is classified as unusual and the required factor of safety for unusual load condition should be at least 1.30-2.60 for ordinary to limited site information category.

3.1.1 Problems Associated with Structurally Connected Pile to Resist Lateral Loads

The use of piles to support lateral load and provide sufficient sliding resistance for a 6.0m high inlet structure which is designed to support difference in water level up to 6.1m is less efficient, especially for slender precast reinforced concrete piles in soft ground. The primary reason for the low lateral capacity of the RC pile is the poor bending capacity of the conventional RC pile. The lateral capacity of the conventional 200 x 200mm (Grade 45) square pile with 4T10 as main reinforcement will only provide allowable lateral capacity of about 7.5kN even for fixed pile head condition (Ultimate lateral capacity = 18.6kN, FOS = 2.5). The lateral capacity is derived based on Broms' method with assumed soil limiting pressure based on Fleming et al., 1992.

The installation of pile at the current soft ground condition also poses significant challenge due to the soft ground conditions, restricting the access of suitable size of piling rig for installation of raked pile or spun pile. Nonetheless, the use of raked piles in soft ground conditions at the pond is not recommended as the consolidation of the soft soil will induce bending moment onto the pile and eventually leads to pile bending failure.

Furthermore, the installation of piles connected to the wall base will reduce the contact pressure between the inlet base with the ground and therefore, the lateral force will eventually be resisted entirely by the piles while the sliding resistance due to the friction between inlet base and ground should be ignored in design as presented in Figure 6.

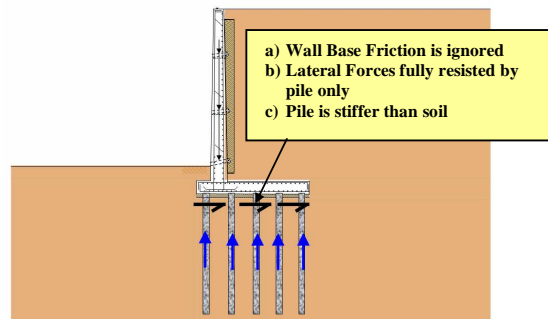

Figure 6 Reinforced Concrete (RC) Wall Supported with Piled Foundation

Based on simple calculation, the lateral loading from combination of the hydrostatic and earth pressure of 433kN/m exerted onto the vertical weir wall (width of 80m) will require total numbers of pile of 4619 to resist the lateral force (Total numbers of piles required = {433kN/m x 80m} / 7.5kN = 4619). As such, it can be seen that significant pile numbers are required just to enhance the lateral load resistance of the inlet and this may not be economically justifiable and practical.

The alternative method of the foundation design for the inlet structure is therefore to introduce piles purely to improve and enhance the stiffness of the soft ground by structurally disconnecting the pile from the inlet wall base, whilst steel sheet pile is adopted as "Passive Shear Key" to enhance the sliding resistance of the inlet while increasing the seepage path at the same time to prevent piping failure of the inlet. This combination of passive resistance of the steel sheet pile with the frictional resistance along the soil-base interface will provide adequate resistance for sliding stability. The main objective of using structurally disconnected piles is to utilise the frictional resistance along the soil-base interface in resisting the lateral loads.

In the design, steel sheet pile is adopted instead of the conventional reinforced concrete (RC) shear key mainly due to the following reasons:-

- Difficult site condition as the construction of RC work involves extensive temporary works for excavation below ground water level.

- b) Sheet pile also provides seepage cut-off to prevent loss of fines and piping failure.
- c) Sheet pile increases the seepage path and provides sufficient safety margin against seepage.

3.2 Disconnected Piled Foundation of Inlet Structure

Due to the soft ground condition with undrained shear strength in the region of 13 to 18kPa, it is necessary to ensure the inlet foundation has an adequate safety factor against bearing failure. As the bearing pressure exerted by the inlet wall typically exceeds 100kN/m², piled foundation is adopted to provide sufficient bearing stability in supporting the inlet wall. It is common practice for pile heads to be connected with, or to penetrate into the base of the structure to form a rigid connection when bearing capacity of the soil is inadequate. But in the current design, the piles are not connected to the inlet wall as it will reduce the frictional resistance along the soil-base interface significantly and the lateral force will then be resisted entirely by the piles. Significant pile numbers will eventually be required to provide sufficient lateral load resistance to resist the hydrostatic and earth pressure exerted to the inlet wall.

Thus to achieve an economical design of the inlet foundation, piles are intentionally disconnected from the inlet wall base. A gap is provided with a layer of 500mm thick crusher run between the pile head and the soffit of the wall base such that the piles would not directly carry the lateral load from the inlet structure. Figure 7 and Figure 8 illustrates the overall layout, section and details of the adopted disconnected piled foundation of SAS inlet structure.

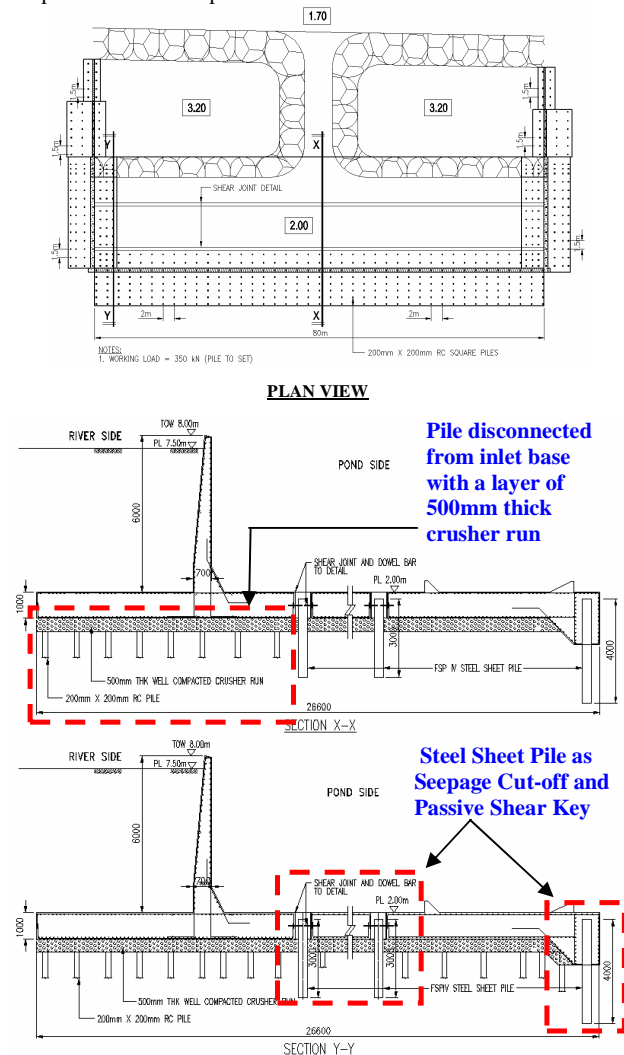

Figure 7 Overall Layout and Section of SAS Inlet Structure

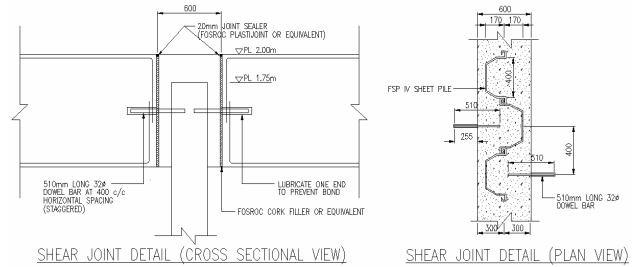

Figure 8 Details of SAS Inlet Structure

The piles are mainly used to act as stiffener for the base soil and to support the axial pressure from the inlet wall, while the sliding resistance is mainly provided by the friction between the wall base and crusher run. The horizontal forces can be effectively resisted through the mobilised frictional forces along the soil-base interface together with the passive pressure against the steel sheet pile incorporated to the inlet structure. Possible structural damage of pile due to poor bending capacity of RC pile can be prevented and the load transmitted to the disconnected pile through the crusher run layer ensures adequate bearing capacity to support axial loading from the inlet structure.

This alternative approach has resulted in considerable reduction in pile quantities for the inlet structure. The design is more cost-effective as it required only 586 numbers of piles against 4619 numbers of piles required in the conventional structurally connected piled foundation. The performance of the disconnected piled foundation system for the inlet has since been proven as the flood detention pond is operational since June 2009.

4. CONCLUSION

Pile foundation is traditionally adopted when bearing capacity of the soil is inadequate in soft ground. The use of pile to support lateral load is less efficient mainly due to the poor bending capacity of the conventional RC pile when it is structurally connected to the wall base. Piled supported structure will reduce significantly the contact pressure along the soil-base interface and as such, the lateral force is resisted primarily by the piles.

The alternative foundation system adopted for the inlet structure is by introducing piles purely to improve and enhance the stiffness of the soft ground. These piles are structurally disconnected from the inlet wall base and sliding resistance is provided by friction along the soil-base interface together with the passive pressure against the steel sheet pile incorporated to the inlet structure.

The use of disconnected piled foundation for the inlet structure is an innovative approach which eventually produces a cost effective, technically viable and construction friendly design. Such approach has resulted in significant reduction in overall pile quantities to resist lateral forces from the combination of hydrostatic and earth pressure exerted to the 6m high inlet structure.

5. REFERENCES

- [1] US Army Corps of Engineer (USACE). Engineering and Design – Stability Analysis of Concrete Structures, EM1110-2-2100, 2005. Chapter 3, pp3/1-3/7
- [2] Fleming, W. G. K., Weltman, A. J., Randolph, M. F. & Elson, W. K., "Piling Engineering", John Wiley & Sons, 1992, Chapter 4, pp150
- [3] Wong, I. H., Chang, M. F. and Cao, X. D. "Raft Foundation with Disconnected Settlement-reducing Pile", Design Application of Raft Foundations, Hemsley, J. A. (ed.), Thomas Telford, 1st edition, 2000, pp469-486.